



BORA

BORA LIGHTING GUIDELINE 2024

More than beautiful lighting.

PERFECT LIGHT PLANNING

LIGHT IS OMNIPRESENT. ELEMENTARY. IT CAN AFFECT PEOPLE'S MOODS AND PERSONAL PERFORMANCE. WE EXPLAIN THE KEY CONSIDERATIONS WHEN PLANNING LIGHT.

DIRECT & INDIRECT LIGHTING	3
COLOUR TEMPERATURE	4
LIGHT TYPES	5
KITCHEN LIGHTING	6
EATING IN THE RIGHT LIGHT	7
AN OVERVIEW OF LIGHT PLANNING	8

Please note:

The plans and notes on lighting design are recommendations that have been adapted to the kitchen plans shown. Lighting design is always individual and should be adapted to the architectural and spatial conditions of the kitchen in question. Your kitchen planner or lighting specialist can help you with this, plan the perfect lighting design for your kitchen.

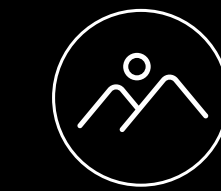

Clear View

Perfectly illuminated without obstructing your view of the contents. Minimalist BORA lighting effectively and elegantly enhances the kitchen while leaving an unobstructed view of the worktop or across the dining table.

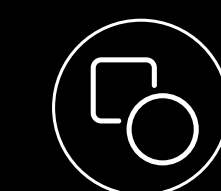

Timeless design

With each model available in three different colours, our lighting rounds out the overall picture of the kitchen with its commitment to timelessly elegant, subtle design.

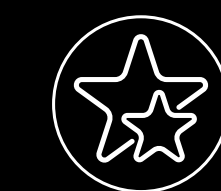

Top performance

A single source for everything and with top quality. BORA lighting rounds out the holistic product range and impresses with excellent colour and brightness capacities.



Simple operation

Our linear pendant light BORA Horizon can be intuitively controlled by gestures. In the three-light versions, the BORA Stars can likewise be variably dimmed via a knob or light switch.

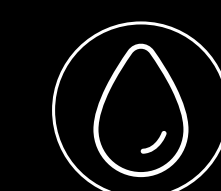

Simple cleaning

Thanks to high-quality materials, the lights are easy to clean with glass cleaner and a damp cloth.



BORA HORIZON
ROSEGOLD



Direct lighting vs. indirect lighting

Direct lighting refers to lights that emit uninterrupted light directly into a room or onto a floor space. This kind of lighting is especially important for rooms that we work in. Indirect lighting is light which isn't emitted straight onto certain objects or areas, but is instead initially reflected off of a wall or an alternative room element. BORA pendant lights are fitted with a diffuser that enables lights to be emitted and broken up by the LED board.

indirect lighting

- ① Optimum ceiling clearance = 0.5 – 1.5 m (depending on the cable length)
- ② Illuminance = 475 lx (at a distance of 1 m)
- ③ Beam angle = 69°

Direct lighting

- ④ Optimum surface clearance = 1.0 – 2.0 m
- ⑤ Illuminance = 1,304 lx (at a distance of 1 m), 326 lx (2 m)
- ⑥ Beam angle = 63°



Colour temperature – warm or cold?

Colour temperature, also called light colour, is a key element when it comes to achieving your desired room ambience. To start with, there are warm whites (2,700 – 3,000 Kelvin) and neutral to cold whites (3,300 – 5,300 Kelvin).

As the colour temperature of the lighting is highly influential on how a room is individually perceived, it's important to choose a light colour that's suitable for the functionality of this room. Warm white light is recommended for living areas like the lounge or bedroom and for the dining room, since creating a cosy atmosphere is particularly important in these places. Wherever concentrated activities like work, writing, cooking and personal hygiene are carried out, it makes sense to employ more neutral to cold white lighting. This includes the bathroom, the kitchen and offices.



Warm white
2,700 Kelvin



Neutral
3,850 Kelvin

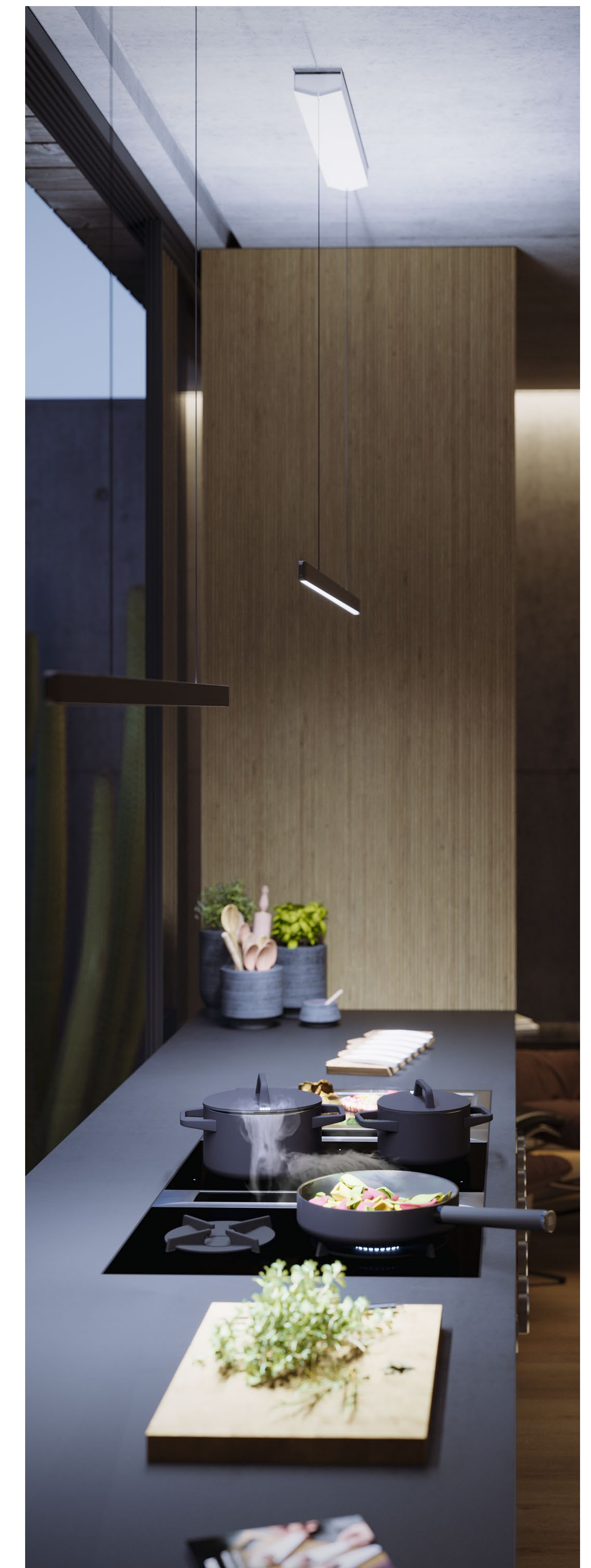

Cold white
5,000 Kelvin



PENDANT LIGHT
BORA HORIZON

PENDANT LIGHT
BORA STARS

To offer maximum flexibility and a wide range of usage options, both over the cooktop and over the dining table, BORA's lighting range encompasses numerous different types of pendant lights.

shop.bora.com/lighting

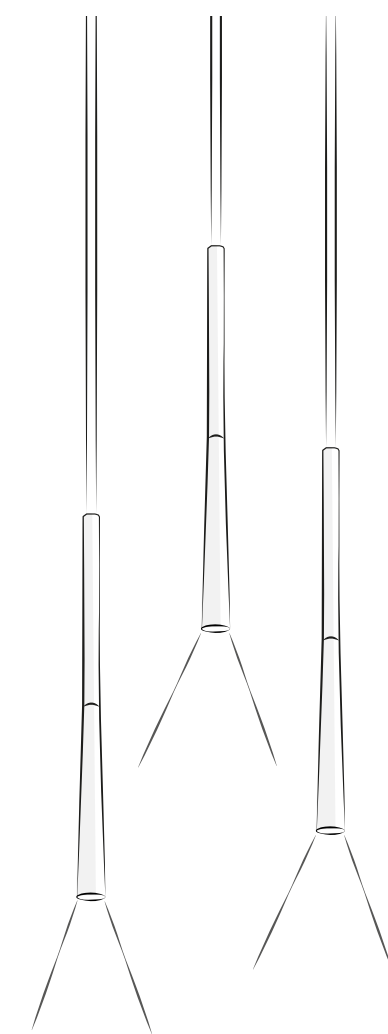

Pendant lights

Pendant lights generally consist of one or more light fixtures which hang from the ceiling on a cable or cord. Unlike ceiling lights, their decorative function and contribution to the ambience of the room tend to be key aspects.

Ceiling lights

Classic ceiling lights are probably the easiest way to illuminate a room. Being attached to the ceiling, they save space and light up the entire room, providing a necessary basic level of light.

That's why ceiling lights are perfect for compensating for the increasing lack of natural light in autumn in that they flood the room with as much interior light as possible.

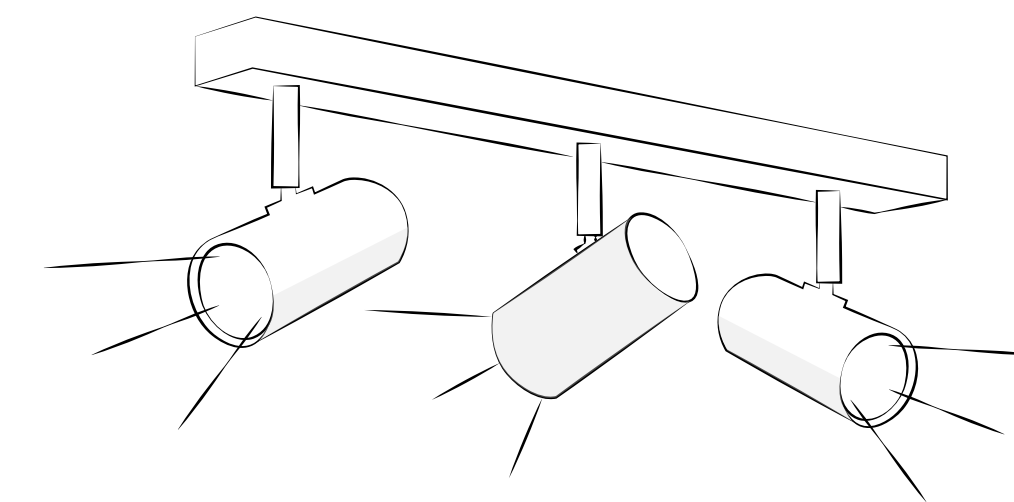
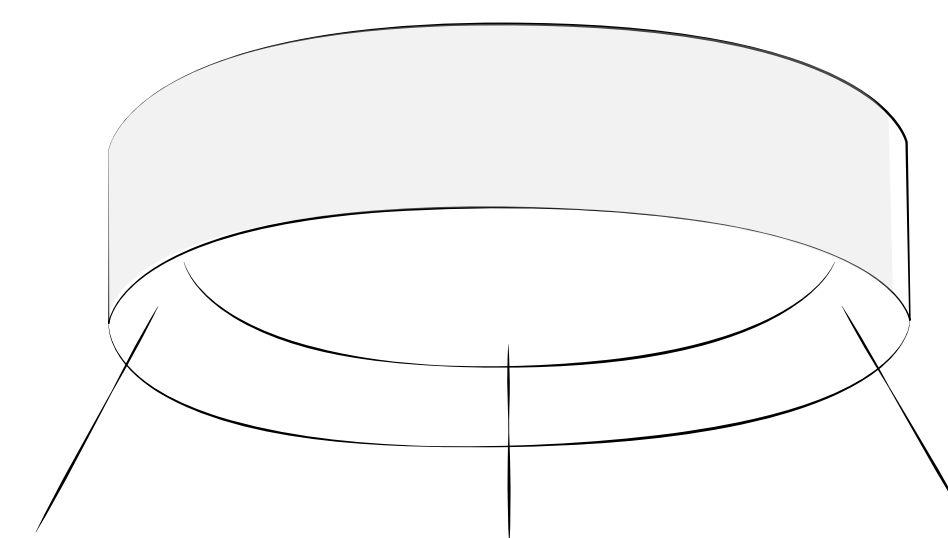

Spotlights

Spotlights serve to direct emitted light onto certain areas. They use lighting accents to highlight and draw special attention to individual elements or sections of a room. Depending on the angle their beams are directed in, spotlights can be used either for targeted and directed lighting or, using a wider beam angle, for directly lighting an entire surface.

Floor lamps

Floor lamps usually consist of a light source, a lampshade and a base. Unlike other types of lighting, floor lamps aren't bound to one location and are highly versatile.

Most of them only provide light to a single part of the room and, in doing so, create cosy pockets of light in living and lounge areas.

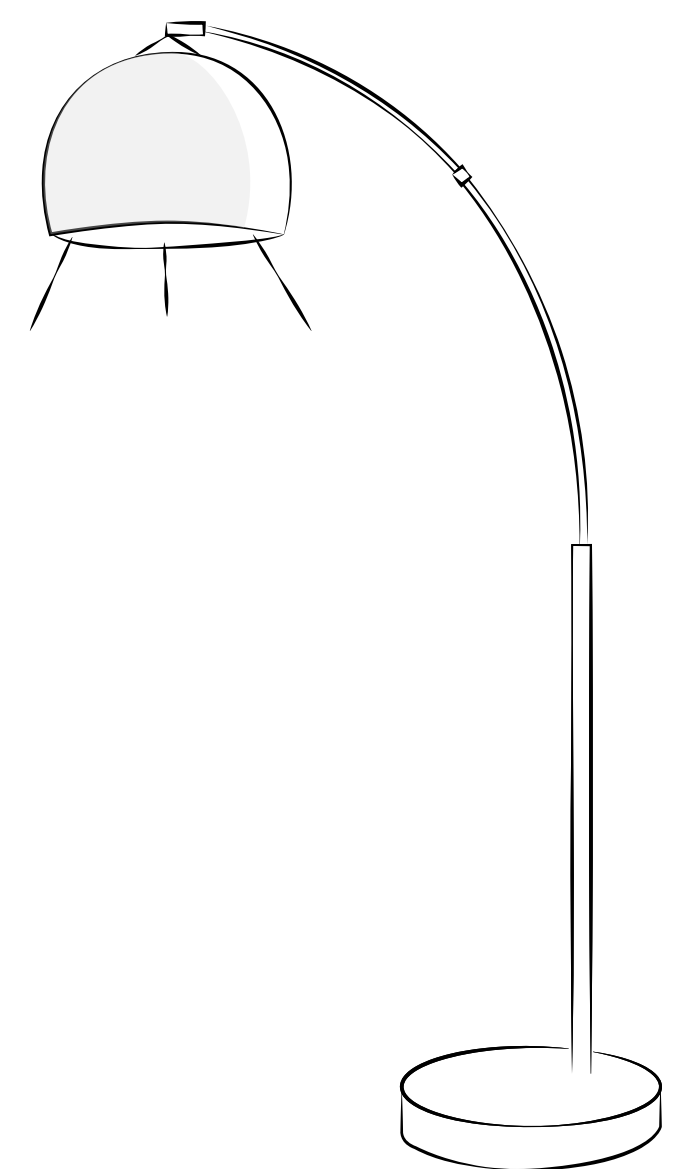

Let there be light – kitchen lighting

Whether daylight, as a natural light source from outdoors, or light fixtures, as artificial, indoor light sources, the planning of kitchen lighting requires creative ideas for well-thought-out results that suit specific workflows and usage situations.

The basics of kitchen light planning

When designing a kitchen, careful consideration should also be given to the lighting. This is because light sources have a high functional, emotional and aesthetic value – from basic lighting (e.g. via dimmable ceiling spotlights) to accent lighting. Functional lighting is particularly important in the kitchen, because areas where people work with knives and other sharp utensils need to be well lit. For this, you could use energy-saving LEDs beneath the cupboards and in the rail system between the worktop and wall units.

In integrated dining areas, the kitchen lighting takes on an emotional role – here atmospheric, subtle lighting is more important than detailed lighting. A decorative ceiling light could be fitted above the dining table to pleasantly brighten up the eating area without dazzling the people sitting around it.

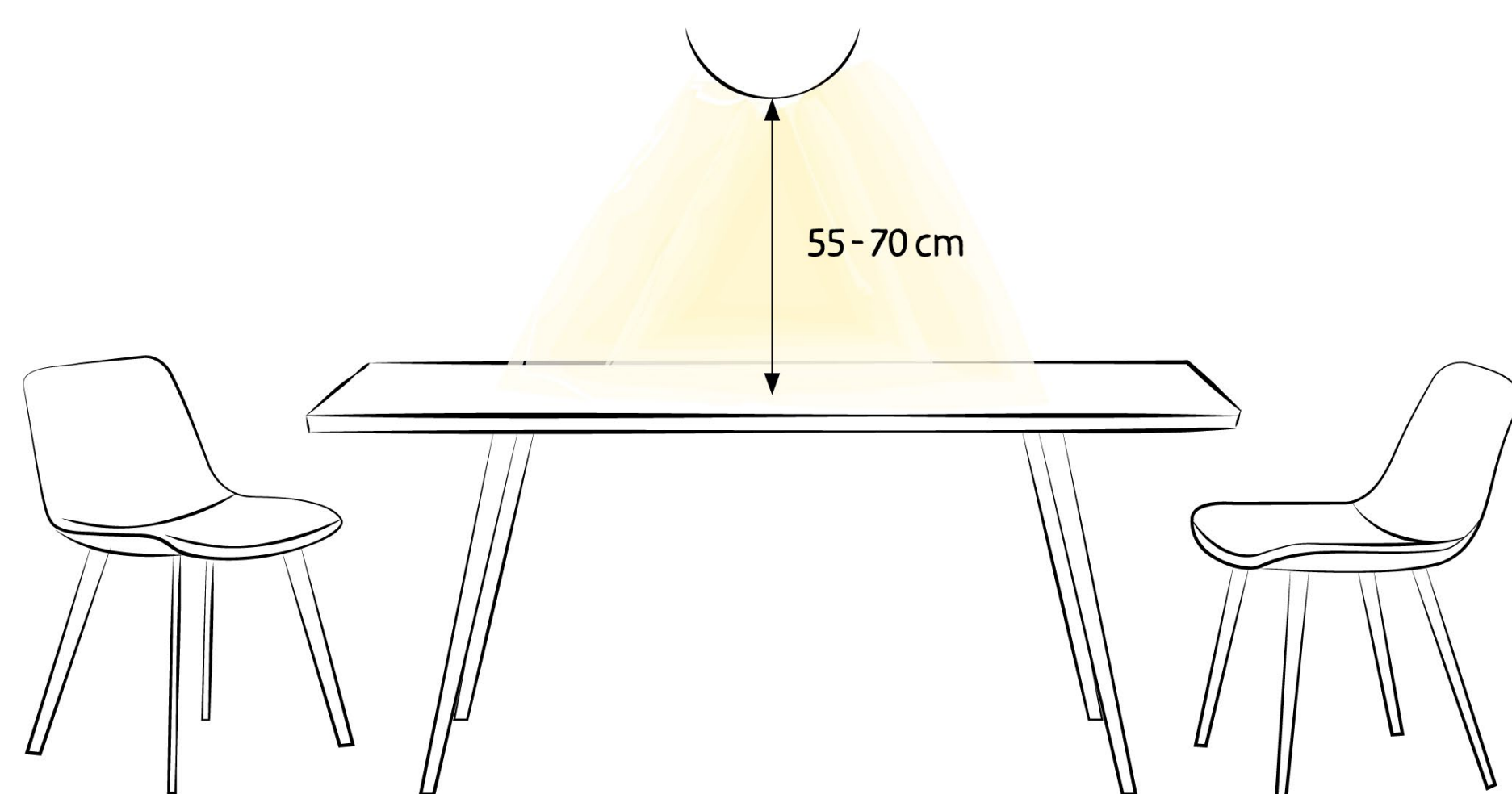

Tip

Dining table lights should hang between 55 cm (minimum) and 70 cm (maximum) above the table top.



Warm white vs. cool white light in the kitchen

When planning the lighting in your kitchen, it's not just a question of where to install the light sources, but also which colour temperature to use.

To recap, the basic rule is that warm white light (2,700 - 3,000 Kelvin) has a calming and relaxing effect, whereas neutral to cool white light (3,300 - 5,300 Kelvin) is similar to daylight and therefore more suitable for functional lighting.

Lighting concepts for kitchens should include both warm white and cold white lights. The former are recommended to create an atmospheric and homely feel, especially at dinner time, and the latter for breakfast time when there isn't enough daylight. Neutral to cool white light also helps you to see clearly while you're concentrating on snipping, washing and cooking. Kitchen lights should be positioned so that they shine directly on the worktop, sink and cooktop.

Perfect kitchen lighting

It may be worth coming up with a floor plan to coordinate the lighting concept according to the different zones. The following aspects need to be considered depending on the size and layout of the room and your kitchen elements:

- Lighting of the dining area
- Light in the kitchen units/on the kitchen island
- Natural light through the windows
- Lit up kitchen appliances

The way you design your lighting depends on the work processes on which your planning is based and that you perform daily at different times of day.

- How much daylight comes in through the kitchen windows?
- Is the kitchen island more for prepping food or eating?
- How many cupboards are integrated into the kitchen units?
- Are there any appliances which also act as a light source?
- How long and how deep is the worktop?

The right lighting above your dining table

Depending on the situation, different lighting arrangements can evoke the broadest range of emotions when eating. Incidentally, it is not just the choice of wall colour that can influence the appetite. The light also affects how appetising food seems. We recommend using warm white light as it has a cosy and calming effect.

For variety and versatility, several lights with selectable shades and dimmable brightness levels can be used. This makes it easy to expand the dining table's functionality, for example by doubling up as a desk. If your lights are height adjustable and dimmable, you can adjust the light to the time of day when you're eating so that you always have the right atmosphere.

Bright, dimmed or dark?

The light that shows off your food to its best advantage can vary. A complex dish whose individual elements are meticulously arranged to form a culinary work of art needs sufficiently bright lighting to stimulate our sense of sight.

If the main aim is to create an intimate setting, the sensual perception of the food is created through a dimmed atmosphere. The sense of sight becomes less important while the senses of taste and smell are fostered. If our perception is restricted, this changes our sensory experience.

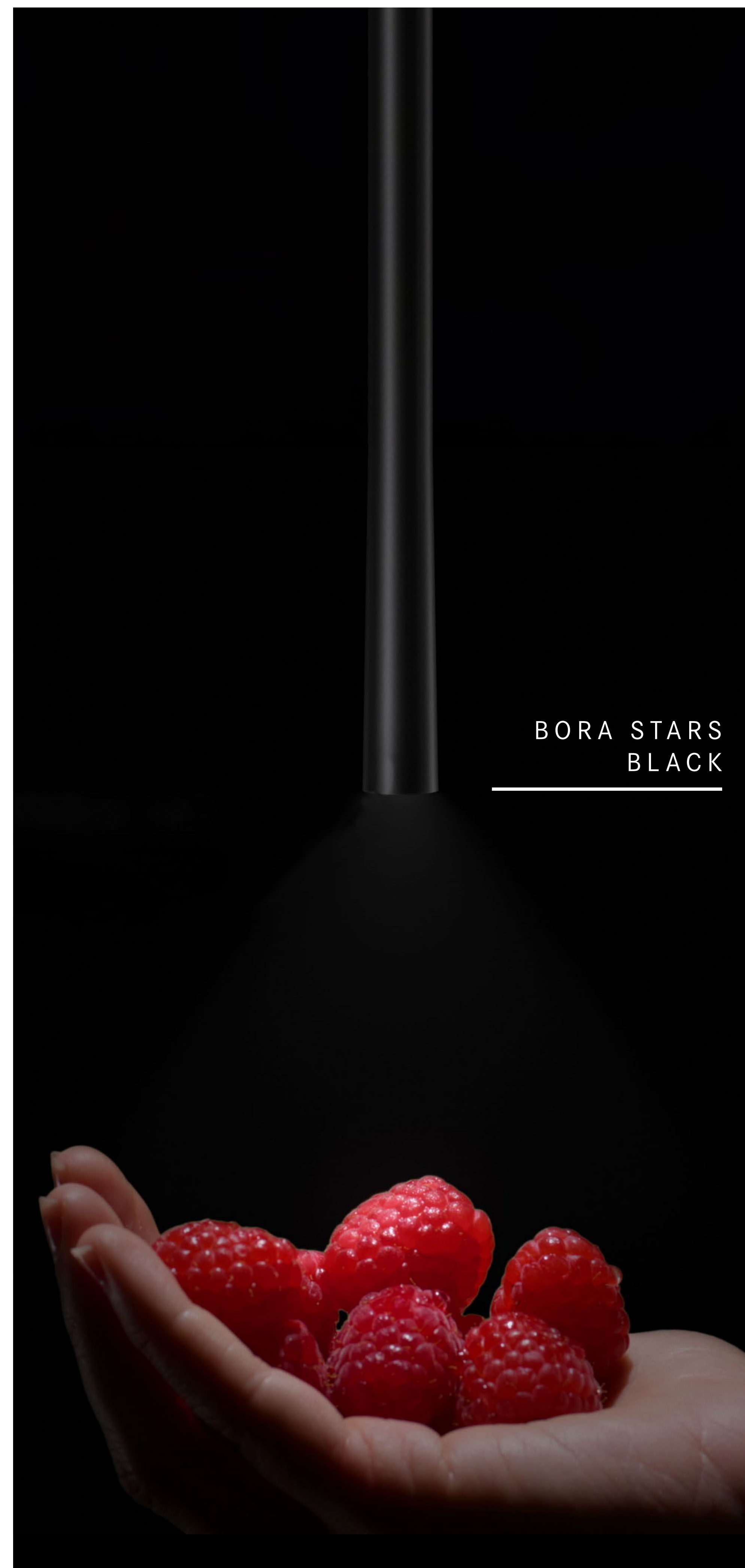

Eating as an exciting sensory journey

Food is a feast for the eyes. When you look at attractively arranged food, it literally makes your mouth water. You can often tell a lot about the freshness, type and consistency of food by its shape and colour. Supermarkets and caterers use this to their advantage.

The colour of fruit and vegetables is very intense with a light temperature of 3,000 Kelvin. Red meat and red fish look fresher in warmer temperatures, whereas white fish looks fresher in cold white light. Cheese and bread look more appetising to many people in warm white light. As you can see, lighting affects our eating habits. Colour associations also convey preferences: we associate yellow with sour flavours and red with spicy tastes.

What effect do different RA values have?

The CRI or RA value refers to the colour rendering index of lights and describes the colour rendering of the (artificial) light source compared to (natural) sunlight. The maximum value of 100 RA describes fully natural colour rendering. If the value drops below 80 RA, the colours appear shrouded by a grey veil.



100 RA



80 RA



60 RA

Functional lighting

The primary aim is to design functional and cosy kitchen lighting that shines direct light on an area where clear visibility is required for more demanding visual tasks.

We therefore recommend using the BORA Horizon linear pendant light over the kitchen island ①.

Depending on the size of the kitchen island or counter, the use of one to three lights is recommended.

For greater flexibility, we recommend using the 'move' version of the BORA Horizon.

Our BORA Stars vertical pendant lights, available in several constellations, look particularly great over the dining table ②.

Tip

A little more light is needed in working areas.

500 lumen (unit for lux) per square metre is a good guide.

Central lighting

Basic lighting should also be provided to ensure that the room is evenly illuminated and generally bright.

This should come from a glare and shadow-free lighting source that emits diffuse light throughout the room. Built-in ceiling spotlights ③ or flexible track lighting systems make ideal choices.

Tip

Ambient lighting does not need to be quite as bright.

300 lumen per square metre is a good guide.

The recommended lumen value can be divided between different light sources.

Light colour and brightness

A neutral white to warm white light with 3,300 – 5,300 Kelvin is recommended for the basic lighting. Warm white light with between 2,700 and 3,300 Kelvin is best for the dining area, above the dining table ④, as this creates a cosy atmosphere.

Neutral white light with around 5,000 Kelvin should be used to illuminate the worktop ⑤ to make working as safe and enjoyable as possible.

The lights can also be dimmed to change the atmosphere in the room, enhance visual comfort or adapt the brightness to the activity or mood.

Tip

If warm white basic lighting is used, the worktop should be illuminated with neutral white light to avoid an extreme contrast.

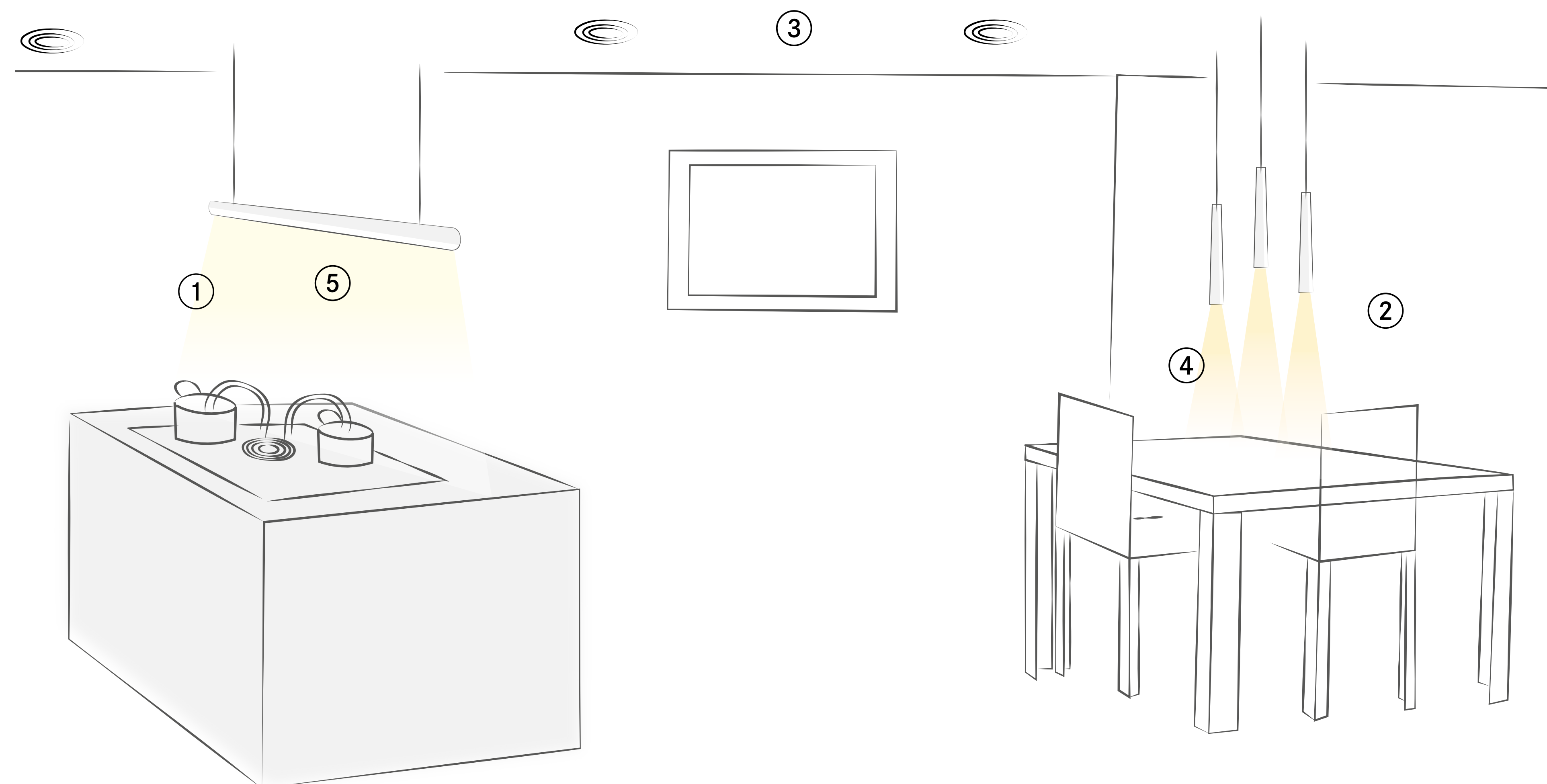

DE

BORA Lüftungstechnik GmbH
Rosenheimer Strasse 33
83064 Raubling
Germany
T +49 (0) 80 35 98 40-0
support@bora.com

A

BORA Vertriebs GmbH & Co KG
Innstrasse 1
6342 Niederndorf
Austria
T +43 (0) 53 73 6 22 50-0
support@bora.com

INT

BORA Holding GmbH
Innstrasse 1
6342 Niederndorf
Austria
T +43 (0) 53 73 6 22 50-0
support@bora.com

EN