

EN Operating and installation instructions XBO



XBOUMIMEN-10006-01

Contents

1	General information	3
1.1	Validity.....	3
1.2	Liability.....	3
1.3	Product conformity.....	3
1.4	Presentation of information.....	3
2	Safety	4
2.1	Intended use.....	4
2.2	People with limited abilities.....	4
2.3	General safety instructions.....	4
2.4	Safety information for installation.....	5
2.4.1	Special safety instructions for using the fresh water connection.....	6
2.5	Safety instructions – operation.....	6
2.6	Safety instructions – cleaning and maintenance.....	8
2.7	Safety instructions – repairs, servicing and spare parts.....	9
2.8	Safety instructions – disassembly and disposal.....	10
3	Technical data	11
3.1	X BO steam oven.....	11
3.1.1	Appliance dimensions.....	11
4	Appliance description	13
4.1	How it works.....	13
4.2	Structure.....	13
4.3	Touch display.....	13
4.3.1	General symbols.....	13
4.4	Opening the door.....	14
4.5	Food thermometer.....	14
4.6	Food supports.....	14
4.7	Demo mode.....	15
5	Functions and operation	16
5.1	Switching the appliance on and off.....	16
5.2	Opening/closing the door.....	16
5.3	Using the food supports.....	16
5.4	Operating the touch display.....	16
5.4.1	How it works.....	17
5.5	Info, tips and instructions.....	17
5.6	Standard functions.....	17
5.7	Global functions.....	17
5.8	Main menu.....	17
5.8.1	Manual.....	17
5.8.2	Presets.....	17
5.8.3	Automatic.....	18
5.8.4	First steps.....	18
5.8.5	Special.....	18
5.8.6	Favourites.....	18
5.8.7	Classic.....	18
5.8.8	Multi-drawer.....	18
5.8.9	Maintenance.....	18
5.8.10	Settings.....	19
5.9	Cooldown.....	19
5.10	How to use the food thermometer.....	19
5.11	Customising the menu.....	19
5.12	Updating the appliance software.....	19
5.13	Activating/deactivating the demo mode.....	19
6	Connect	20
6.1	Installing the app.....	20
6.2	Pairing.....	20
6.3	BORA JOY app.....	20

7	Cleaning and maintenance	21
7.1	Cleaning the cooking chamber.....	21
7.1.1	Manual cleaning.....	21
7.1.2	Maintenance programmes.....	21
7.1.3	X BO cleaning cartridge.....	21
7.2	Cleaning the food thermometer.....	22
7.3	Cleaning the appliance front.....	22
7.4	Cleaning food supports.....	22
7.5	Cleaning the drain filter.....	22
7.6	Cleaning the oven chamber seal.....	22
7.7	X BO odour filter.....	22
7.7.1	Filter change.....	22
8	Troubleshooting	23
9	Installation	24
9.1	Installation information.....	24
9.1.1	Fitted unit.....	24
9.1.2	Fresh water connection.....	24
9.1.3	Waste water connection.....	24
9.2	Scope of delivery.....	24
9.3	Tools and aids.....	24
9.4	Installation dimensions.....	24
9.5	BORA X BO frame spacer.....	25
9.5.1	Removing the frame spacer.....	26
9.5.2	Fitting additional frame spacers.....	26
9.6	Installation.....	27
9.6.1	Fitting unit mounting plates.....	27
9.6.2	Appliance connections.....	27
9.6.3	Water drainage.....	27
9.6.4	Fresh and waste water connection.....	28
9.6.5	Power supply.....	28
9.6.6	How to connect the BORA multi-drawer (optional) ...	29
9.6.7	Positioning the operating unit.....	29
9.6.8	Installing and securing the appliance.....	29
9.6.9	Fitting the odour filter.....	29
9.7	Ventilation.....	30
9.8	Initial operation.....	30
9.9	Handover to user.....	30
10	Decommissioning, disassembly and disposal	31
10.1	Decommissioning.....	31
10.2	Disassembly.....	31
10.3	Environmentally-friendly disposal.....	31
10.3.1	Disposal of transport packaging.....	31
10.3.2	Disposal of accessories.....	31
10.3.3	Disposal of the old appliance.....	31
11	Warranty, technical service, spare parts, accessories	32
11.1	BORA manufacturer's warranty.....	32
11.1.1	Warranty extension.....	32
11.2	Service.....	32
11.3	Spare parts.....	32
11.4	Accessories.....	32
12	Product datasheet	33
13	Information for testing institutes	34

1 General information

These instructions and all accompanying documents contain important information to protect you from injury and prevent damage to the appliance.

► Please by all means adhere to all documents that form part of the scope of delivery.

Assembly, installation and commissioning must always occur in line with national laws, regulations and standards. The work must be performed by qualified specialists who know and comply with the additional regulations of the local energy supply companies.

All safety and warning information as well as the handling instructions in the accompanying documents must be observed.

Please keep these instructions in a safe place and pass them on to the next owner where applicable.

1.1 Validity

These instructions apply to several appliance versions. It is therefore possible that some of the features described do not apply to your appliance. The details of the figures contained herein may differ and are to be understood as schematic diagrams.

1.2 Liability

. BORA Holding GmbH, BORA Vertriebs GmbH & Co KG, BORA APAC Pty Ltd and BORA Lüftungstechnik GmbH – hereinafter referred to as BORA – do not assume any liability for damage arising from disregard for or non-adherence to the documents included in the scope of delivery!

Furthermore, BORA shall not be held liable for damage caused by improper installation or failure to observe the safety and warning information!

1.3 Product conformity

The appliances comply with the following EU/EC regulations:

- 2009/125/EC Ecodesign Directive
- 2011/65/EU RoHS Directive

BORA Vertriebs GmbH & Co KG hereby declares that the X BO radio equipment complies with directive 2014/53/EU.

The appliance supports the following frequency bands:

- 2.4 GHz: 100 mW max.
- 5 GHz: 100 mW max.

	AD	AT	BE	CH	CZ	EN	DK	EE	ES
	FI	FR	IE	IT	LI	LU	MC	MT	NL
	NO	PL	PT	RO	SE	SI	SK	SM	UK(NI)

In these countries, the following applies in the case of 5 GHz Wi-Fi: only for indoor use.

The appliances comply with the following UK regulations:

UK – Statement of Compliance The Product Security and Telecommunications Infrastructure (Security Requirements for Relevant Connectable Products) Regulations 2023.

The full text of the EU declaration of conformity and the UK statement of compliance is available at the following address:

<https://www.bora.com>

1.4 Presentation of information

The article described in these instructions is hereinafter also referred to as an appliance. All measurements are provided in millimetres.

Operating instructions

► Always follow all instructions in the prescribed order.

Enumerations

- Enumeration 1
- Enumeration 2

Info points



 Information notes point to special features that must be taken into account.

Safety and warning information

 DANGER
Type and source of danger
Results of non-compliance
► Measures to minimise risk

Please note:

- warning symbols draw attention to a high risk of injury.
- The signal word indicates the severity of that risk.

Warning symbol	Signal word	Risk
	Danger	Indicates an immediate, hazardous situation which causes death or serious injury if not respected.
	Warning	Indicates a potentially hazardous situation which can cause death or serious injury if not respected.
	Caution	Indicates a potentially hazardous situation which can cause minor injury if not respected.
	Note	Indicates a potentially hazardous situation which can cause property damage if not respected.

Tab. 1.1 Meaning of the warning symbols and signal words

2 Safety

The appliance complies with the stipulated safety requirements. The user is responsible for the safe use of the appliance, cleaning and maintenance. Improper use can lead to personal injury and damage to property.

2.1 Intended use

The appliance is solely intended for preparing food in private households.

i The appliance may only be operated in frostproof rooms.

This appliance is not intended for:

- professional use (catering)
- outdoor use
- heating rooms
- use in mobile installation sites such as motor vehicles, ships or aeroplanes
- use at altitudes of over 2000 m (metres above sea level)
- use when not fully installed

Any other use or any use that goes beyond that which is described here is classed as unintended.

i BORA does not assume any liability for damages caused by incorrect installation, improper use or incorrect operation.

All misuse is prohibited!

2.2 People with limited abilities

Children

The appliance can be used by children aged 8 and over if they are supervised or have been instructed how to use the appliance safely and understand the resultant risks. Children must not play with the appliance.

- ▶ Use the child lock in order to prevent children from switching on the appliance or changing the settings when they are unattended.
- ▶ Supervise children in the vicinity of the appliance.
- ▶ Do not store any items that could be of interest to children in storage spaces above or behind the appliance or in the oven chamber. Otherwise, they will be tempted to climb onto the appliance (open door).

i Any work involving cleaning and maintenance must not be carried out by children unless they are supervised at all times while doing so.

People with reduced physical, sensory or mental capacities

The appliance can be used by people with reduced physical, sensory or mental capacities or a lack of experience and/or knowledge if they are supervised or have been instructed how to use the appliance safely and understand the resultant risks. Operation can be restricted using the child lock.

2.3 General safety instructions

⚠ DANGER

Packaging components are a choking hazard

Packaging components (e.g. film, polystyrene) can be life-threatening for children.

- ▶ Store all packaging components out of reach of children.
- ▶ Dispose of the packaging properly and immediately.

⚠ DANGER

Risk of electric shock or injury from damaged surfaces

The underlying electronics can be exposed or damaged due to fissures, fractures or cracks in appliance surfaces (e.g. damaged glass), particularly in the vicinity of the operating unit. This can cause an electrical shock. Furthermore, a damaged surface can cause injuries.

- ▶ Do not touch the damaged surface.
- ▶ If there are any cracks, fissures or fractures, switch the appliance off immediately.
- ▶ Securely disconnect the appliance from the mains using the circuit breaker, fuses, automatic circuit breakers or contactor.
- ▶ Contact the BORA Service Team.

⚠ DANGER

Risk of injury from overloading the open door

The maximum load capacity of the open door is 22.5 kg.

- ▶ Make sure that children do not stand or sit on or hang from the open door.
- ▶ Do not stand, sit or lean on the open door.
- ▶ Do not place any heavy objects on the open door.

⚠ WARNING

Risk of injury or damage due to incorrect components or unauthorised modifications

Incorrect components can lead to personal injury or damage to the appliance. Modifications, additions or alterations to the appliance can lead to safety risks.

- ▶ Only use original components.
- ▶ Do not make any modifications, additions or alterations to the appliance.

⚠ WARNING**Risk of injury due to mechanical damage on the appliance**

Mechanical damage (e.g. cracks, deformation, separation of adhesive seals, etc.) to the appliance, as well as to cables and accessories can cause injuries.

- ▶ Do not operate the appliance.
- ▶ Do not try to repair or replace damaged components yourself.
- ▶ Contact the BORA Service Team.

CAUTION**Appliance components can cause injury if dropped**

Appliance components can cause injury if you drop them.

- ▶ Place any appliance components that have been removed in a safe place near the appliances.
- ▶ Ensure that no components removed from the appliances can fall on the floor.

CAUTION**Risk of injury from heavy lifting**

If not handled correctly, carrying and installing appliances can cause injury to the limbs or torso.

- ▶ If necessary, carry and install the appliance with another person.
- ▶ Use appropriate aids to prevent damage or injury.

CAUTION**Damage from improper use**

The appliance surfaces must not be used as work or storage surfaces. This can damage the appliances (particularly in the case of hard and sharp objects).

- ▶ Never use the appliances as work or storage surfaces.
- ▶ Keep hard or sharp objects away from the appliance surfaces.

PLEASE NOTE**Appliance damage due to covered temperature sensor**

If the temperature sensor in the oven chamber is covered and therefore obstructed, e.g. by a food support that has been inserted too high up, the appliance may overheat and become damaged.

- ▶ Ensure that the oven chamber sensor is not covered and remains unobstructed.
- ▶ Ensure that the oven chamber sensor is clean and stick to the specified cleaning intervals.

PLEASE NOTE**Faults and errors**

In the event of faults or incorrect use, error messages will be displayed.

- ▶ In the case of faults and errors, follow the instructions on the appliance display and in the “Troubleshooting” chapter.
- ▶ In the event of any faults or errors that are not mentioned, switch the appliance off and contact BORA Service.

PLEASE NOTE**Appliance damage caused by pets**

Pets may damage the appliance or injure themselves.

- ▶ Keep pets away from the appliance.

2.4 Safety information for installation**⚠ DANGER****Risk of injury from incorrect assembly**

Failure to observe the installation instructions can lead to injury.

- ▶ The appliance must only be installed and assembled by trained specialists who are familiar with and comply with the standard national regulations and supplementary regulations of the local utility companies.
- ▶ The appliance may only be installed with the power disconnected.
- ▶ Work on electrical components must only be conducted by trained electrical personnel.
- ▶ Conduct all work extremely attentively and conscientiously.
- ▶ Before handing the appliance or system over to the end user, ensure that it has been correctly installed.

⚠ DANGER**Risk of electric shock from incorrect mains connection**

Connecting the appliance to the mains incorrectly poses a risk of electric shock.

- ▶ Make sure that the appliance has a fixed connection to the mains voltage.
- ▶ Make sure that the appliance is connected to a properly installed protective conductor system.
- ▶ Make sure that technical equipment is provided to enable all of the appliance's poles to be disconnected from the mains with a contact opening width of at least 3 mm (circuit breaker and automatic circuit breakers, fuses, contactor).

⚠ DANGER**Risk of electric shock from damaged power supply cable**

If the power supply cable is damaged (e.g. during installation), this can cause an (lethal) electric shock.

- ▶ Make sure that the connection cable does not become trapped or damaged.

⚠ DANGER**Risk of electric shock from damaged appliance**

A damaged appliance can cause an electric shock.

- ▶ Check the appliance for visible damage prior to installation.
- ▶ Do not install or connect any damaged appliances.
- ▶ Do not operate any damaged appliances.

PLEASE NOTE**Appliance damage caused by incorrect wiring**

The electrical safety of the appliance is only guaranteed if it is connected to a protective conductor system that has been installed in line with regulations.

- ▶ Work on electrical components must only be conducted by trained electrical personnel.
- ▶ Ensure that this basic safety precaution is met. The appliance must be suitable for the regional voltage and frequency.
- ▶ Check the information on the identification plate and in the event of deviations, do not connect the appliance.
- ▶ Only use the connection cables supplied.

2.4.1 Special safety instructions for using the fresh water connection**⚠ WARNING****Risk to health from unpurified water**

The use of unpurified water poses a risk to health

- ▶ Connect the appliance to the drinking water supply.
- ▶ Ensure that the quality of the fresh water complies with the drinking water regulations in the corresponding country.
- ▶ The fresh water connection may be only be fitted by trained specialists who are familiar with and comply with the local regulations.

CAUTION**Damage caused by dirt in the water**

Dirt in the water pipe can be deposited in the appliance valve. If this affects the functioning of the valve, water can leak out.

- ▶ Rinse out the water pipe before connecting the appliance or when work is carried out on the water pipes.

2.5 Safety instructions – operation**⚠ DANGER****Risk of fire from overheated oil or fat**

Oil or fat in the pot can quickly heat up and ignite.

- ▶ Never leave the appliance unattended when cooking with oil or fat.
- ▶ Never extinguish oil and fat fires with water.
- ▶ Switch off the appliance.
- ▶ Extinguish the fire using a pan lid or a fire blanket, for example.

⚠ DANGER**Risk of fire from overdrying**

When food is overdried there is a risk of fire.

- ▶ Do not leave the appliance unattended if you are desiccating or drying herbs, bread, mushrooms, etc.
- ▶ If you see smoke, keep the appliance closed and switch off the electricity supply.
- ▶ Do not open the door until the smoke has gone.

⚠ DANGER**Risk of burns or explosion caused by flammable liquids**

Flammable liquids (alcohol fumes) can be ignited in the hot oven chamber or explode and cause serious injuries.

- ▶ Never prepare dishes with large amounts of high-proof alcoholic beverages.
- ▶ Only use small amounts of high-proof beverages.
- ▶ Do not pour flammable liquids (e.g. spirits) over hot food.

⚠ DANGER**Risk of burns or explosion caused by closed preserve jars**

Heating closed preserve jars leads to excessive pressure which can cause the jars to explode and cause serious injuries.

- ▶ Do not heat closed preserve jars.

⚠ WARNING**Risk of burns from hot food**

Food may spill over when inserting or removing the food support. Touching hot food can cause serious burns.

- ▶ Ensure that no hot food spills over when inserting or removing the food support.

⚠ WARNING**Risk of burns due to power cut**

During or after a power cut a cooktop that was previously in operation may still be hot.

- ▶ Do not touch the appliance while it is still hot.
- ▶ Keep children away from the hot appliance.

⚠ WARNING**Risk of burns from hot surfaces**

The appliance and exposed parts (oven chamber, door, heating elements, food thermometer, accessories) become hot during use. Touching hot surfaces can cause serious burns.

- ▶ Do not touch hot surfaces.
- ▶ Please use suitable accessories when needed (pot holders, oven gloves).
- ▶ Keep children under 8 years of age away from the appliance or ensure they are supervised at all times.

⚠ WARNING**Risk of injury from moving appliance parts**

There is a risk of injury when opening and closing the door or operating unit.

- ▶ Ensure that nobody reaches into the appliance when the door or operating unit is being opened or closed (children in particular).

⚠ WARNING**Risk of injury from open door**

When the door is open there is a risk of tripping or crushing.

- ▶ Close the door after use.

⚠ WARNING**Risk of corrosion**

Rusting materials (e.g. platters, cutlery) can cause corrosion in the oven chamber.

- ▶ Only use original accessories in the oven chamber.

⚠ WARNING**Risk of injury from hot steam**

Hot steam can escape when the door is opened if the steam has not been extracted beforehand. Depending on the temperature, steam may be invisible. After opening, hot water may drip from the door.

- ▶ When opening the door, do not stand too near to the appliance.
- ▶ Open the door carefully.
- ▶ Keep children away from escaping steam.

⚠ WARNING**Risk of injury from the food thermometer if not used carefully**

Failure to take care when inserting the food thermometer in the food can lead to puncture wounds.

- ▶ Ensure that the food thermometer is correctly positioned.

PLEASE NOTE**Appliance damage**

Incorrect use may cause damage to the appliance.

- ▶ Ensure that the drain filter is always used when cooking. Large food residues can block the water outlet pipe and the pump.
- ▶ Never line the oven chamber with aluminium foil or oven liners.
- ▶ Do not place any cookware directly on the floor of the oven chamber.
- ▶ Do not store any flammable objects or liquids in the oven chamber.
- ▶ Keep the door closed during use, as otherwise the controls get very hot.
- ▶ Always catch dripping grease in a suitable container.
- ▶ Switch off the appliance after use.

PLEASE NOTE**Increased humidity**

During cooking and cleaning, moisture is released into the ambient air.

- ▶ Ensure a sufficient supply of fresh air, e.g. by opening a window.
- ▶ Ensure a normal and comfortable room climate (humidity of 45–60%), e.g. by opening natural ventilation openings or using domestic ventilation systems.

2.6 Safety instructions – cleaning and maintenance

 DANGER**Risk of fire from overheated oil or fat**

Oil or fat in the pot can quickly heat up and ignite.

- ▶ Remove any oil or fat residues from the oven chamber before use.

 WARNING**Risk of burns from hot surfaces**

The appliance and exposed parts (oven chamber, door, heating elements, food thermometer, accessories) become hot during cleaning. Touching hot surfaces can cause serious burns.

- ▶ Do not touch hot surfaces.
- ▶ Allow the appliance and exposed parts to cool before and after cleaning.
- ▶ Keep children under 8 years of age away from the appliance or ensure they are supervised at all times.

 WARNING**Risk of corrosion**

Food or liquid containing cooking salt which becomes stuck to the stainless steel walls of the oven chamber can cause corrosion.

- ▶ Remove any such food or liquid from these surfaces.

 WARNING**Risk of injury from hot steam**

Hot steam can escape when the door is opened if the steam has not been extracted beforehand. Depending on the temperature, steam may be invisible. After opening, hot water may drip from the door.

- ▶ When opening the door, do not stand too near to the appliance.
- ▶ Open the door carefully.
- ▶ Keep children away from escaping steam.

 WARNING**Risk of injury from hot water and cleaning agents**

Opening the door during the cleaning programme may cause burns or eye irritation.

- ▶ Do not open the door during the cleaning programme.

CAUTION**Eye irritation from cleaning agent residues**

Cleaning agent residues in the oven chamber and the empty cleaning cartridge can cause irritation if it comes into contact with the eyes.

- ▶ Wash your hands after touching cleaning agents or the cleaning cartridge.

PLEASE NOTE**Appliance damage due to soiled appliances**

Dirt can lead to damage, restriction of functions, or bothersome odours. In the worst case scenario, this can become a hazard.

- ▶ Clean the appliance regularly.
- ▶ Remove dirt immediately.
- ▶ When cleaning, only use non-abrasive detergents to prevent scratching and abrasion on the surface.
- ▶ When cleaning, ensure that no water penetrates the appliance. Use only a slightly damp cloth. Never spray the appliance with water. Water penetration can cause damage.
- ▶ Do not use a steam cleaner for cleaning. Steam can cause a short circuit on live parts and thus lead to property damage.
- ▶ Please follow all instructions in the “Cleaning and Maintenance” chapter.
- ▶ Do not use any highly-abrasive cleaning products or sharp metal scrapers to clean the oven chamber and glass surfaces (door and operating unit). This can scratch the surfaces and damage the glass.
- ▶ Use only original BORA cleaning cartridges, as cartridges from other manufacturers can cause irreparable damage to the appliance.

2.7 Safety instructions – repairs, servicing and spare parts** DANGER****Risk of injury when carrying out repairs**

Insufficient expertise can lead to injury when carrying out repairs.

- ▶ The appliance must only be repaired and serviced by trained specialists who are familiar with and comply with the standard national regulations and supplementary regulations of the local utility companies.
- ▶ Safely disconnect the appliance from the mains supply.
- ▶ Work on electrical components must only be conducted by trained electrical personnel.
- ▶ A damaged power supply cable must be replaced by a suitable power supply cable.
- ▶ Old hose sets must not be reused for connecting the water supply.

 DANGER**Risk of electric shock from residual charge**

Electrical components in the appliance can contain residual charge and cause an electric shock.

- ▶ Do not touch any exposed contacts.
- ▶ Use the discharge adapter before starting work on the appliance.

 WARNING**Risk of injury or damage from improper repairs**

Incorrect components can lead to personal injury or damage to the appliance. Modifications, additions or alterations to the appliance can lead to safety risks.

- ▶ Only use original spare parts for repairs.
- ▶ Do not make any modifications, additions or alterations to the appliance.

2.8 Safety instructions – disassembly and disposal

DANGER

Risk of injury during disassembly

Insufficient expertise can lead to injury when disassembling the appliance.

- ▶ It must only be disassembled by trained specialists who are familiar with and comply with the standard national regulations and supplementary regulations of the local utility companies.
- ▶ Safely disconnect the appliance from the mains supply.
- ▶ Work on electrical components must only be conducted by trained electrical personnel.

DANGER

Risk of electric shock from incorrect disconnection

Incorrectly disconnecting the appliance from the mains results in a risk of electric shock.

- ▶ Safely disconnect the appliance from the mains supply.
- ▶ Use an authorised measuring device to ensure that there is no power to the appliance.
- ▶ Do not touch exposed contacts on the electronic unit as they may contain residual charge.

DANGER

Risk of electric shock from residual charge

Electrical components in the appliance can contain residual charge and cause an electric shock.

- ▶ Do not touch any exposed contacts.
- ▶ Use the discharge adapter before starting work on the appliance.

3 Technical data

3.1 X BO steam oven

Parameter	Value
Multiphase supply voltage	380-415 V 2N
Supply voltage 1-phase	220-240 V
Frequency	50 Hz
Maximum power consumption	6100 W
2-phase fuse protection/power supply	2 x 16 A
1-phase fuse protection/power supply	1 x 16 A
Dimensions (width x height x depth)	598 x 599 x 580 mm
Oven chamber dimensions (width x height x depth)	480 x 308 x 405 mm
Cooking chamber volume	53 L
Number of shelf levels	3
Weight (incl. accessories/packaging)	62 kg
Weight (net)	47 kg
Surface material	Glass and plastic
Temperature control range	30-230 °C
Power management	seamless
Length of water inlet pipe	2.5 m
Water inlet pipe connection	3/4" (spanner size 30)
Internal/external diameter of water drainage pipe	19 mm/27 mm
Odour filter material	Activated charcoal with ion exchanger
Maximum filter service life	1 year
Guaranteed availability period for software updates (from product discontinuation date)	5 years

Tab. 3.1 X BO technical data

3.1.1 Appliance dimensions

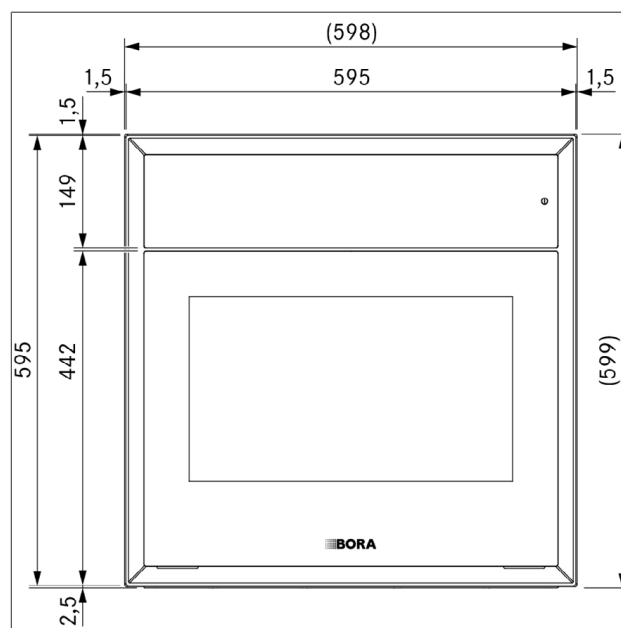

Fig. 3.1 X BO front view

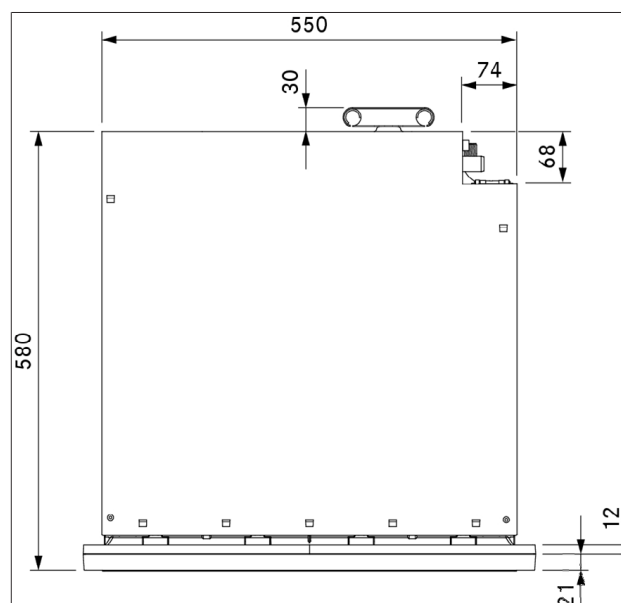

Fig. 3.2 X BO top view

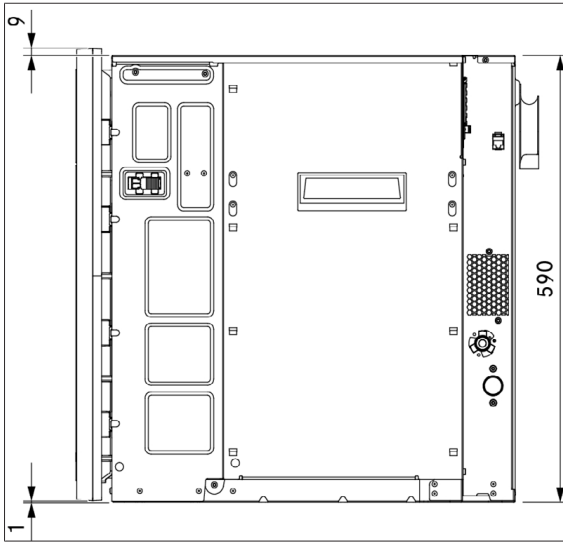

Fig. 3.3 XBO side view

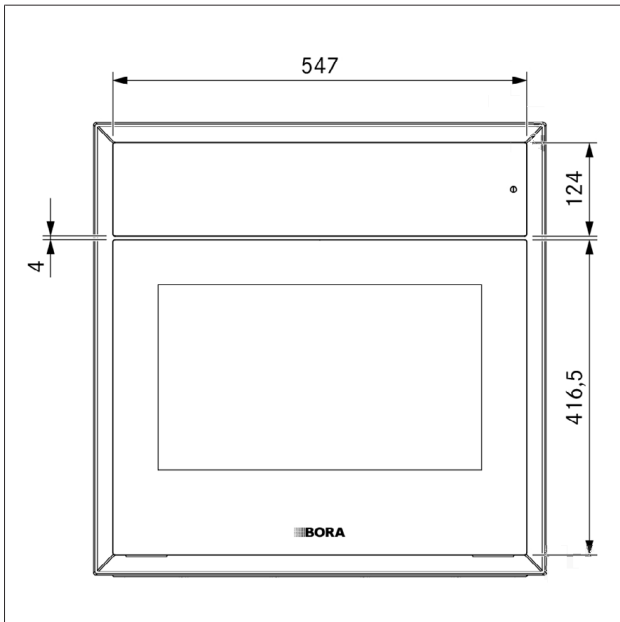

Fig. 3.4 XBO glass front view

4 Appliance description

► Observe all safety and warning information (see "2 Safety").

4.1 How it works

- Steamer and oven in a single appliance
- Steam extraction straight from the oven chamber
- Very fast readjustment
- Cooking processes require comparably less heat
- Hot air is circulated at high speed
- Faster cooking process
- Optimum and consistent cooking results
- Activated charcoal odour filter provides for fresh air

4.2 Structure

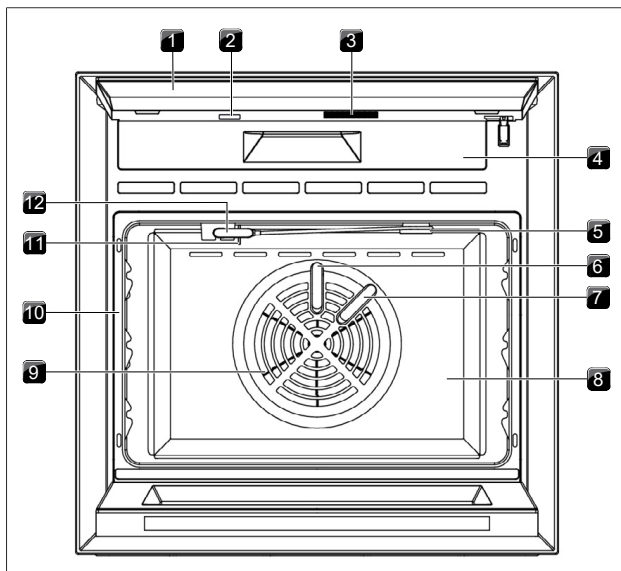

Fig. 4.1 Structure part 1

- [1] Operating unit with touch display (raised)
- [2] USB interface
- [3] Speaker
- [4] Filter replacement cover
- [5] Food thermometer cable holder
- [6] Cleaning water inlet
- [7] Steam water inlet
- [8] Oven chamber (made entirely of stainless steel)
- [9] Fan wheel
- [10] Oven chamber seal
- [11] Oven chamber temperature sensor
- [12] Food thermometer

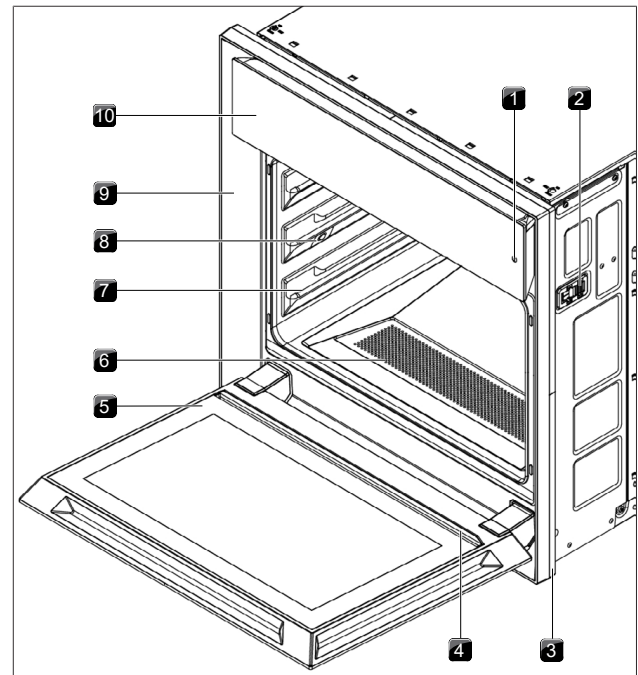

Fig. 4.2 Structure part 2

- [1] On/off sensor button
- [2] Levelling shim (x 2)
- [3] Frame spacer
- [4] Drip channel
- [5] Door (open)
- [6] Drain filter
- [7] Oven chamber shelves (3 shelf levels)
- [8] LED oven chamber lighting (x 3)
- [9] Inlay frame
- [10] Operating unit with touch display (closed)

4.3 Touch display

The appliance is controlled using a touch display. To make it easier to use, the operating unit and touch display can be seamlessly raised or closed.

- Hold each side of the operating unit with one hand.
- Tilt the operating unit up or down.

i Pointed or sharp objects can scratch the surface of the touch display.

i No water or dirt must get behind the touch display.

4.3.1 General symbols

Symbol/function	Meaning
BORA Choice	Meets BORA nutrition guidelines
Action	User action necessary
Plus	Add function
Tick	Confirmation
Continue	Go to
End	Cancel
Start	Starting the function

Symbol/function	Meaning
● Stop	Pause function
⌚ Timed cooking	Cook for a set time
🍴 Core temperature	Cook with food thermometer
⌘ No core temperature	No core temperature selected
⋮ Scroll wheel	Change to scroll wheel view
⊞ Slider	Change to slider view
👉 Stop steam extraction	Stop steam extraction, open door immediately
💨 Burst of steam	Add burst of steam
⊘ No burst of steam	Not possible to add burst of steam
🌡 Temperature	Temperature settings
💧 Humidity	Humidity settings
📄 Copy automatic programme	Create copy in "Own programmes"
🔄 Changed automatic programme	Automatic programme with changed cooking parameters
❤ Favourite	Preferred programme
❄ Frozen	Programme for frozen food

Tab. 4.1 General symbols

4.4 Opening the door

BORA Smart Open

Once the pre-opening system has been activated, the steam is extracted from the oven chamber. The door will then open. (BORA Clear View – prevents steam from escaping when the door is opened). The steam extraction duration can be set (10–20 seconds). The door can also be opened manually without steam extraction.

4.5 Food thermometer

Thanks to the four-point food thermometer, you can reliably determine the core temperature of the food. It is located at the top of the oven chamber and is connected to the appliance by a cable. The food thermometer is inserted into the food. The four measuring points detect the coldest part of the food at all times. Once the food has reached the target temperature, the cooking process is ended automatically.

4.6 Food supports

All food supports can be used on all shelf levels. The food supports required for a programme are indicated as accessories in the presets, pro tips and special programmes.

Universal tray

- Material: aluminium, coated with extremely hard ceramic, PFOA-free non-stick outer coating
- Size (W x D x H): 469 × 354 × 25 mm
- Capacity: 3 L

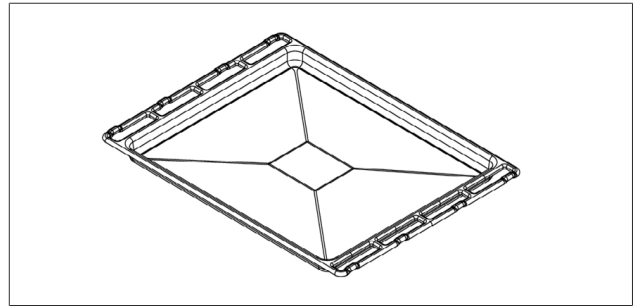

Fig. 4.3 Universal tray

Deep universal tray

- Material: aluminium, coated with extremely hard ceramic, PFOA-free non-stick outer coating
- Size (W x D x H): 469 × 354 × 40 mm
- Capacity: 4.9 L

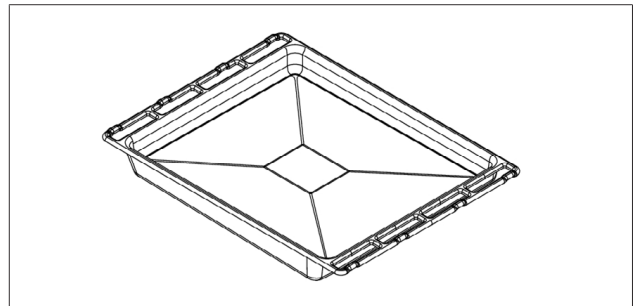

Fig. 4.4 Deep universal tray

Perforated stainless steel tray

- Material: stainless steel
- Size (W x D x H): 469 × 361 × 41.5 mm
- Capacity: 5.2 L
- More consistent cooking results thanks to improved air and steam circulation
- Excess grease or liquids drip down and are caught by placing a universal tray underneath
- Suitable for gently cooking all kinds of foods

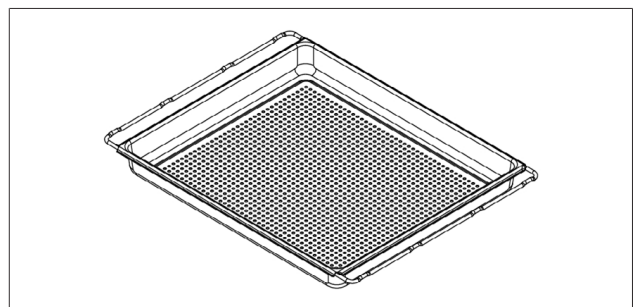

Fig. 4.5 Perforated stainless steel tray

i The perforated stainless steel tray is not suitable for frozen foods and can only be used for temperature settings up to 120 °C.

Oven rack

- Material: stainless steel
- Size (W x D x H): 469 × 358 × 38.5 mm
- The raised edge on the oven rack prevents the food from sliding off (shelf with the raised edge on the front).

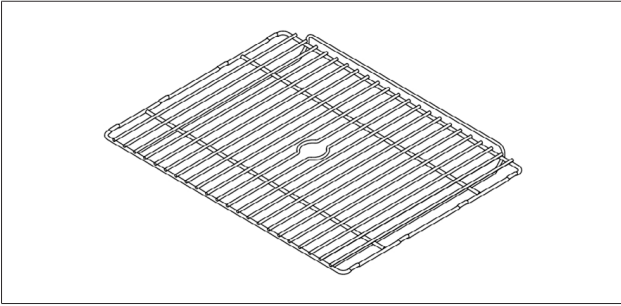

Fig. 4.6 Oven rack

i When running the cleaning programme, the oven rack is used as a support for the cleaning cartridge.

4.7 Demo mode

There are three demo modes to choose from with limited functions:

- No heat or water
- Water but no heat
- Video sequence – oven cannot be operated

5 Functions and operation

► Observe all safety and warning information (see "2 Safety").

5.1 Switching the appliance on and off

The sensor button ① reacts to finger contact. You switch the appliance on and off with this button.

- Long press on ①.
 - When turned off, the appliance is temporarily switched to sleep mode and after 15 minutes the software is completely shut down.

i When the appliance is operated, the drain filter must be fitted. Large food residues can block the water drainage pipe and the pump.

5.2 Opening/closing the door

Opening the door

- Tap 
 - The door opens slightly.
- Use both hands to open the door as far as it will go.

i If you do not do this within 10 seconds of the door opening, it will close again automatically.

Closing the door

When the door is fully open:

- use both hands to tilt the door upwards until the automatic function closes the door.

When the door has been pre-opened:

- Use both hands to open the door as far as it will go.
- use both hands to tilt the door upwards until the automatic function closes the door.

i do not push the door closed when pre-opened; this may damage the appliance.

5.3 Using the food supports

Inserting/removing food supports

- Place the food support on the shelf guides at the required level and push until it comes to a stop in the oven chamber.

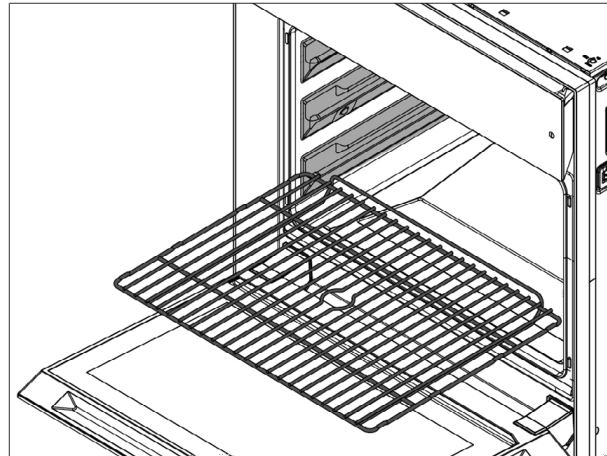

Fig. 5.1 Inserting food supports

The food supports have a protection mechanism that prevents them from sliding out of the front of the shelf guide.

- Lift the food support to take it out.

How to use food supports carefully and correctly

- Do not use knives on the food supports.
- Do not use any metal or sharp objects to turn or remove food.
- Only use plastic or wooden kitchen utensils.

Food supports may expand when heated (thermal behaviour). If heated unevenly, the metal will expand to different extents. The measures below can be taken to prevent warping:

- Preheat the X BO without the food supports.
- Load the food supports evenly.
- Use the food supports as instructed.
- Use a suitable tray or tin for pizzas, round cakes and similar and place this on the oven rack.
- Avoid placing cold food or water directly on hot food supports.
- Use the universal tray for searing and roasting.

5.4 Operating the touch display

The touch display reacts to finger contact. It recognises different touch commands:

Touch command	Contact	Duration
Touch	Brief touch	0.5 s
Long press	Longer contact	1–8 s
Swipe	Swiping motion (vertical + horizontal)	0.1–8 s
Number scroll wheel	Vertical swiping motion over the number scroll wheel (until the desired value is in the centre)	

Tab. 5.1 Touch commands

- Only touch the display with your fingers.
- Make sure that your fingers are clean and dry before using the touch controls.
- Ensure that no other parts of your hand are touching the display when using the controls.
- Keep the contact area as small as possible when using the touch zones.

A scroll bar on the bottom edge of the display shows the area that is currently visible in the menu.

- Swipe left or right across the display to show other areas in the menu.

5.4.1 How it works

Operation	Command
Touch	Select a function, button or menu item
Long press	Activate additional options
Swipe	Set value, navigation

Tab. 5.2 Operating principle

5.5 Info, tips and instructions

i The menu item “First steps” contains helpful videos on how to operate and handle the X BO steam oven.

Information and tips

The programmes provide practical information and tips:

- ▶ Touch  in the presets
- ▶ Touch the “Info” button under “Special programmes”
- ▶ Touch the “Pro tip” button under “Automatic programmes”

Instructions





When you press the “Instructions” button, an animation will explain how to do certain things (e.g. inserting the BORA cleaning cartridge).

Status messages

Shown on the top edge of the display.
▶ Please take note of status messages.

5.6 Standard functions







Standard functions are available on every menu level and are shown at the edge of the display.

Symbol/function	Meaning
 Back one menu level	The next menu up is displayed
 Main menu	The main menu is displayed
 Open the door	The door is opened automatically
 Oven chamber lighting	Oven chamber lighting on/off
Time	Hour:minute

Tab. 5.3 Standard functions

5.7 Global functions

Global functions can be used at any time.

Symbol/function	Meaning
 Egg timer	Countdown in seconds, acoustic and visual signal when the time lapses; the time will then continue to run in minus figures
 Alarm	Acoustic signal at a certain time; the time will then continue to run in minus figures
 Search	Free text search with suggestion function
 Message	Information for other people, message on the display (e.g. Do not stop the cooking session)
 Operating lock	Prevents unintentional or unauthorised operation
 Cleaning lock	The display is locked for 10 seconds

Tab. 5.4 Global functions

Accessing global functions











▶ Swipe downwards from the top edge of the display.

Closing global functions

▶ Swipe upwards.

5.8 Main menu

The different functions and settings are selected from the main menu. Other options are displayed under some of the menu points or settings can be made.

Symbol/function	Meaning
 Manual	Manual cooking
 Automatic	Automatic programmes
 First steps	Learn how to use the oven (can be hidden under “Settings”)
 Special	Other useful programmes
 Favourites	Favourite automatic programmes
 Classic	Classic cooking
 Multi-drawer	BORA multi-drawer control (only if a multi-drawer is connected)
 Maintenance	Maintenance programmes and filter changes
 Settings	Appliance settings
 Basics	Simple automatic programmes (function only found in guest mode – see “Settings”)

Tab. 5.5 Main menu

5.8.1 Manual

The target humidity and temperature as well as the cooking time can be precisely preset using two selectable views (slider or scroll wheel). The optional manual burst of steam can also be activated separately. Temperature specifications that refer to conventional oven functions (e.g. top/bottom heat, grill) and are not available on the appliance can be adapted according to the following rules of thumb:

Temperature range of conventional ovens	Manual cooking setting
120–140 °C	5 °C lower
140–160 °C	10 °C lower
160–180 °C	15 °C lower
180–230 °C	20 °C lower



Tab. 5.6 Conversion table

5.8.2 Presets

Under the “Manual” and “Classic” menu items, presets have been saved with cooking parameters that can be changed manually if necessary.



A range of presets is available such as “Crisp up rolls”, “Steam vegetables”, “Braise joint”, etc. There is practical info on each preset.

Selecting presets

- ▶ Touch “Manual”  or “Classic” .
- ▶ Touch .
- ▶ Touch the desired preset.
- ▶ Change the settings if necessary.

5.8.3 Automatic

In the case of automatic programmes, the optimal temperature, cooking time and addition of steam are preset. To guarantee the desired cooking results, starting conditions are displayed for many programmes (e.g. temperature or nature of the food). In some programmes, the suggested values for the degree of browning and done level (e.g. firm, al dente, soft) can be adjusted. Automatic programmes can be changed separately and saved under new names. Pro tips give useful advice on how to prepare the dish.

-  Place the food in the steam oven at room temperature. Allow frozen foods to defrost first.
-  High temperatures are used for some automatic programmes (up to 230 °C). Unsuitable fats or oils can cause smoke to form. We therefore recommend using fats and oils with a high smoke point.

Changing automatic programmes

The values of individual cooking steps can be changed in the cooking step display.

- ▶ Swipe up from the bottom edge of the display in the automatic programme.
- ▶ Select the cooking step.

The modified automatic programme can be saved when the programme ends.

Starting an automatic programme from a certain cooking step

- ▶ Swipe upwards from the bottom edge of the display.
- ▶ Select the cooking step.
- ▶ Touch “Start programme here”

Starting automatic cooking programmes later

In programmes that can be started later, the start and end time can be changed (see “First steps”).

Automatic programme layout in terms of quantity (guide values)

- Standard setting: 4 servings/4 people
- Traybakes: 1 tray
- Meat dishes: 800–1000 g meat (raw weight)
- Bread, baked goods: approx. 750 g baked goods
- Rice, risotto: 300–400 g dry rice without liquid

5.8.4 First steps

Helpful videos with simple explanations on how to operate and handle the appliance.

- ▶ Touch “First steps” .
 - ▶ Touch the video.
- End the video early:
- ▶ Long press on the display.

5.8.5 Special

Menu item with useful special programmes such as “Keep warm”, “Defrost”, “Sous-vide cooking”, “Drying”, etc.

5.8.6 Favourites

Favourite automatic programmes can be saved under this menu item.

Add favourites





Go to the desired automatic programme.

- ▶ Long press on the dish.
- ▶ Touch .

5.8.7 Classic

With the Classic function, all conventional cooking methods can be used: roasting, baking, steaming and hot air grilling. These work by simply combining hot air and steam.

-  Where temperatures and times are given on food packaging, use the lowest values.

Symbol/ operating mode	Function
 Hot air	The intense flow of hot air evenly browns dishes.
 Bake with humidity	Water is added to the hot airflow to create a humid environment in the oven chamber; dishes do not dry out as much and remain moist
 Steam	Temperature up to 100 °C, maximum humidity, a particularly gentle cooking method; cooking at a lower temperature retains the natural flavourings, nutrients and vitamins
 Hot air grill	Targeted removal of moist air from the oven chamber and the addition of fresh air intensively browns the food and favours the formation of cooking residues
 Eco mode	Less power, therefore reduced energy consumption, only hot air, no addition of steam, longer heating-up times

Tab. 5.7 Classic operating modes

Operating mode	Particularly suitable for...
Hot air	Baked goods (cakes, bread, biscuits), ready meals
Bake with humidity	Casseroles, meat and fish dishes, cheesecakes, dry cakes
Steam	Vegetables, fish, tender meat, dumplings
Hot air grill	Grilled meat, grilled sausages, grilled vegetables, cooking dishes au gratin

Tab. 5.8 How to use the classic operating modes

5.8.8 Multi-drawer

If the appliance is installed along with a BORA multi-drawer, the latter can be controlled and operated using the X BO touch display.

5.8.9 Maintenance

The appliance has programmes for cleaning and drying and for changing the odour filter (see “Cleaning and maintenance”).

5.8.10 Settings

Individual settings can be made on the appliance under this menu item.

- i** Standard code for deactivating guest mode and the child lock: 2021

5.9 Cooldown

The Cooldown function quickly cools the oven chamber with water and brings it back to the desired target temperature. A Cooldown is automatically suggested when the temperature in the oven chamber is higher than the set target temperature. When setting a programme, you can choose from dry or wet Cooldown options according to the next cooking step.

5.10 How to use the food thermometer

- ▶ Take the food thermometer out of the holder.
- ▶ Insert the food thermometer into the thickest part of the food.
 - In the case of food containing bones, insert it right next to the bone.
 - When cooking whole poultry, insert along the breastbone.
- ▶ When you have finished cooking, clean the food thermometer, put it back in its holder and wrap the cable around the cable holder.

5.11 Customising the menu

The symbols in the following menus can be rearranged according to personal requirements:

- Main menu
- Automatic
- First steps
- Special
- Maintenance

How to move symbols



- ▶ Press and hold the symbol and drag it to the desired position.

5.12 Updating the appliance software

Using a USB stick

The latest software is available on the BORA website free of charge (www.bora.com).



- i** A USB stick with FAT32 formatting is needed to save the update file.

- ▶ Load the update file onto the USB stick.
- ▶ Touch “Settings” .
- ▶ Perform the update under “System and updates” .
 - After restarting automatically, the appliance will confirm the update.



Via Wi-Fi

When a new software version is available, the status message “Update available” appears in the display.

- i** To perform an update via Wi-Fi, the appliance must be connected to the Internet.

- ▶ Touch the status message “Update available”
- or
- ▶ Touch “Settings” .
- ▶ Perform the update under “System and updates” .
 - After restarting automatically, the appliance will confirm the update.

Call up information about the Wi-Fi update

- ▶ Touch “Settings” .
- ▶ Touch “System and updates” .
- ▶ Touch  next to “Latest SW”.

5.13 Activating/deactivating the demo mode

Activating the demo mode.

- ▶ Touch “Settings”.
- ▶ Touch “System and updates”.
- ▶ Touch “Serial number” five times.
- ▶ Enter the pin “2007” and confirm.
- ▶ Select a demo mode.
- ▶ Activate the demo mode.

Deactivating the demo mode

- ▶ Touch “Demo mode” on the display.
- ▶ Deactivate the demo mode.
- ▶ Enter the pin “2007” and confirm.

- i** Before deactivating demo mode, the fresh water supply must be connected and the water supply checked.

Deactivating the video sequence

- ▶ Long press on the touch display.
- ▶ Enter the pin “2007” and confirm.

6 Connect



6.1 Installing the app

The BORA JOY app is free to download from the Google Play Store™ or Apple App Store®.

- ▶ Install the BORA JOY app on your smartphone.

6.2 Pairing

How to enable connectivity on the X BO

- ▶ Touch “Settings” 
- ▶ Touch “BORA Connect” 
- ▶ Follow the instructions on the appliance.

How to connect to the BORA JOY app

- ▶ Open the BORA JOY app on your smart phone.
- ▶ Select the desired BORA appliance and start connection.
- ▶ Confirm connection.

6.3 BORA JOY app

Connection with the BORA JOY app provides access to additional features and information. The BORA JOY app contains the exact recipes for the automatic programmes on the BORA X BO. The latter can also be conveniently controlled via the app.

Direct link to the corresponding recipe

- ▶ Access the automatic programme on the BORA X BO.
- ▶ Touch “Open recipe in app”.
- ▶ Scan the QR code.

The corresponding recipe is opened in the BORA JOY app.

Direct link to the corresponding automatic programme

- ▶ Open the required recipe in the BORA JOY app.
- ▶ Touch “Cook now”.

The corresponding automatic programme is accessed.

The automatic programme is started when confirmed on the X BO:

- ▶ Touch “Start” 

7 Cleaning and maintenance

► Observe all safety and warning information (see "2 Safety").

i Regular cleaning and maintenance ensures long service life of the product and optimal function.

► Adhere to the following cleaning intervals:

Component	Cleaning interval
Oven chamber	Quick clean/manual cleaning: as required Intensive cleaning: as required or after a certain period of use (indicator on the appliance) Drying: when there is moisture in the oven chamber
Food thermometer	Immediately after every soiling
Appliance front	Immediately after every soiling
Inner door glass	Immediately after every soiling
Food supports	After every use
Drain filter	Immediately after every soiling
Oven chamber seal	As required, after preparing poultry
Odour filter	Replace yearly (indicator on appliance)

Tab. 7.1 Cleaning intervals

- Never use steam cleaners, abrasive sponges, scouring pads or chemically aggressive cleaning agents (e.g. oven cleaner spray).
- Make sure that the cleaning agent does not contain any sand, soda, acids, lyes or chloride.
- Do not use dishwasher tabs to replace the X BO cleaning cartridge.

i The appliance should be cleaned before long periods of absence (e.g. holiday).

i If the cleaning intervals are not observed, functions may be restricted.

7.1 Cleaning the cooking chamber

7.1.1 Manual cleaning

- Clean the oven chamber with a clean sponge cloth and warm water.
- Dry the oven chamber by hand with a soft cloth.

i Water must not be poured inside the oven chamber.

7.1.2 Maintenance programmes

The appliance is equipped with automatic cleaning programmes and a drying programme.

Quick clean

This short cleaning programme is above all suitable for a quick clean when the appliance is only slightly soiled, limescale is present or after cooking highly aromatic dishes.

Intensive cleaning

This automatic cleaning programme thoroughly cleans and descales the oven chamber with hot water and the environmentally friendly active ingredients in the X BO cleaning cartridge. When using the intensive cleaning function, the cleaning cartridge is placed in the centre of the oven rack.





Intensive cleaning should be carried out every two to four weeks, depending on how often the oven is used. A bar underneath the "Intensive cleaning" symbol shows the time remaining until the next clean is to be carried out.

i An intensive cleaning cycle can only be started when the appliance has cooled to below 40 °C. Wait for the oven to cool before inserting the cleaning cartridge.

i The cleaning time may vary due to a number of factors (e.g. fresh water temperature, power supply).

i If the power goes off during an intensive clean, an automatic rinse will be required when the appliance is restarted and the cleaning cartridge must be removed.

How to start the cleaning programme

- Remove all food supports from the oven chamber before starting the programme.
- Remove the drain filter.
- Clean the oven rack by hand.
- Remove any large residues such as pieces of food from the oven chamber.
- Before cleaning, check that the oven chamber seal is positioned correctly.
- Touch "Maintenance" .
- Touch "Intensive cleaning"  or "Quick clean" .
- Proceed as shown when you press the "Instructions" button.
- Touch "Start" .

After cleaning, the oven chamber will be dried automatically.



How to finish an intensive cleaning cycle:

- Remove any cleaning residues from the oven chamber, especially from the oven chamber floor, the inner glass and the oven chamber seal.
- If necessary, remove any stubborn residues that have not been removed by the cleaning programme.
- Insert the drain filter in the oven chamber.
- Dry the oven chamber seal by hand with a soft cloth.

i Smoke and odours may be evident when heating up the appliance for the first time after cleaning.

Drying

If the oven chamber is not soiled, but merely damp from steam, the drying programme will suffice. This uses warm, dry air to remove residual moisture from the oven chamber.

- Touch "Maintenance" .
- Touch "Dry" .
- Dry the oven chamber seal by hand with a soft cloth.

7.1.3 X BO cleaning cartridge

The X BO cleaning cartridge with its environmentally friendly active ingredients is required for the intensive cleaning and quick clean functions on the X BO. Its dual chamber system enables the oven to

be cleaned and descaled in a single cycle. The cartridge is made from a recyclate, which can be disposed of as plastic waste after use and recycled.

- i** Detailed instructions for use are provided with the X BO cleaning cartridge upon delivery.
- i** You can obtain the X BO cleaning cartridge XBORK from your specialist retailer or from the BORA shop via the website www.mybora.com.

7.2 Cleaning the food thermometer

Manual cleaning

- ▶ Clean the food thermometer with a clean sponge cloth, washing-up liquid and warm water.
- ▶ Dry the food thermometer with a soft cloth.

Automatic cleaning

The food thermometer is also cleaned during an intensive cleaning cycle and quick clean.

7.3 Cleaning the appliance front

- ▶ Clean the appliance front with a clean sponge cloth, washing-up liquid and warm water or with a clean, damp microfibre cloth with no cleaning products.
- ▶ Dry the front of the appliance with a soft cloth.

7.4 Cleaning food supports

Manual cleaning

- ▶ Use a cleaner and degreaser in one.
- ▶ Clean the food supports with hot water and a soft brush.
- ▶ Rinse the food supports well.
- ▶ Dry the food supports with a soft cloth.

Cleaning in the dishwasher

- ▶ Lay the food supports face down in the dishwasher.
- ▶ Ensure that no other objects can rub against the food supports.

7.5 Cleaning the drain filter

Manual cleaning

- ▶ Use a cleaner and degreaser in one.
- ▶ Clean the drain filter with hot water and a soft brush.
- ▶ Rinse the drain filter well.
- ▶ Dry the drain filter with a soft cloth.

Cleaning in the dishwasher

- ▶ Place the drain filter in the dishwasher.

7.6 Cleaning the oven chamber seal

- ▶ Clean the oven chamber seal and drip channel with a clean sponge cloth, washing-up liquid and warm water or with a clean, damp microfibre cloth with no cleaning products.
- ▶ Dry the seal and drip channel with a soft cloth.

- i** A soiled oven chamber seal can cause leaks.

7.7 X BO odour filter

So that odours are effectively reduced, the filter must be replaced on a regular basis. A bar underneath the filter change symbol shows the time remaining until the odour filter is to be changed.

- i** You can obtain the X BO odour filter XBOGF from your specialist retailer or the BORA shop via the website www.mybora.com.

7.7.1 Filter change

- ▶ Touch "Maintenance" .
- ▶ Touch "Filter change" .
- ▶ Proceed as shown when you press the "Instructions" button.

Activating the odour filter

After changing the filter, the new odour filter must be activated.

- ▶ Touch the button "Activate new filter".
- ▶ Confirm the filter change.

8 Troubleshooting

i You can often remedy faults and errors yourself. This saves time and money as you don't need to call out customer services.

i In the event of a fault, the appliance informs users via its display. Further assistance and suggested solutions can be accessed via a QR code. You can also find them at www.bora.com under "Service". This enables you to resolve most issues promptly.

Operating situation	Cause	Remedy
Appliance cannot be switched on	Fuse/automatic circuit breaker defective	Replace the fuse; Switch the automatic circuit breaker back on
	The fuse/automatic circuit breaker trips several times	BORA Contact the Service Team.
	The power supply is disconnected	Have a specialist electrician inspect the power supply
There is no water supply to the appliance	The dirt filter in the water inlet pipe is blocked	Clean the dirt filter in the water inlet pipe
Steam escapes during use	The oven chamber seal is not in the correct place	Check that the oven chamber seal is in the correct place
	The oven chamber seal is heavily soiled	Clean the oven chamber seal
	The oven chamber seal is damaged	Contact the BORA Service Team
During use, a noise (gurgling) can be heard coming from the trap	The trap is not correctly ventilated	Clean the drainage pipe, contact the pipe cleaning service
The oven chamber lighting is not working	The oven chamber lighting is faulty	Contact the BORA Service Team
Water is leaking from the appliance	The oven chamber seal is not in the correct place	Check that the oven chamber seal is in the correct place
	The water inlet pipe or water drainage pipe is faulty	Switch off the appliance, close the fresh water supply stop cock, turn the appliance off at the fuse box, contact the BORA Service Team
	The pipe connection on the appliance is faulty	
Water is dripping into the oven chamber	Particles have caused the valve to leak	Do not disconnect the appliance from the power grid, close the fresh water supply stop cock, contact the BORA Service Team

Tab. 8.1 Troubleshooting

Faults and errors not covered:

- ▶ Switch off the appliance.
- ▶ Contact the BORA Service Team (see "11 Warranty, technical service, spare parts, accessories") and enter the error number displayed and the appliance type.

9 Installation

► Observe all safety and warning information (see "2 Safety").

9.1 Installation information

- The installation height of the appliance must be such that the contents of the food support on the top shelf level can be seen.
- To prevent the appliance from shifting or tipping over, it must be installed inside a fitted unit.
- Handle recesses are provided at the sides for carrying the appliance.

9.1.1 Fitted unit

- The back panel of the kitchen unit must not be fitted behind the appliance.
- To prevent overheating, the appliance must not be installed behind a decorative door.
- An unobstructed ventilation cross-section of at least 160 cm² must be provided in the unit.
- A minimum distance of 30 mm is to be maintained between the back of the appliance and any adjacent structure.
- If two X BOs are installed one on top of the other, a stable built-in shelf or appliance mounting brackets must be provided for.
- The appliance must not be installed underneath a hob.

Additional installation instructions for Australia and New Zealand (AU/NZ)

- The appliance may only be installed in a tall unit.
- Minimum installation height: 850 mm from the ground.

9.1.2 Fresh water connection

- The appliance must have a mains water connection.
- The appliance must be connected to the fresh water supply (cold water) (3/4" connection thread).
- The stopcock for the fresh water supply must be easily accessible when the appliance is installed.
- Only use the water supply hose provided. There must be no kinks in the hose and it must not be shortened, extended or replaced with another hose.
- The water supply hose must not be flush-mounted.

Inlet water pressure

The water inlet pressure must be at least 200 kPa (2 bar). The appliance is designed to withstand a maximum water inlet pressure of 600 kPa (6 bar). If the pressure is greater than 600 kPa (6 bar), a pressure regulator must be installed to ensure seamless operation.

9.1.3 Waste water connection

- The water outlet pipe must either be connected to a surface or flush-mounted trap with a permanent hose connection, or to the appliance connection on the sink trap.
- The waste water temperature can be up to 95 °C.
- The trap must be easily accessible when the appliance is installed.
- Only use the water outlet hose provided. There must be no kinks in the hose and it must not be shortened or lengthened.
- The water outlet hose must not be flush-mounted.

9.2 Scope of delivery

Scope of delivery	Quantity
X BO steam oven	1
X BO oven rack	1
X BO perforated stainless steel tray	1
X BO universal tray	1
X BO deep universal tray	1
X BO cleaning cartridge	1
X BO odour filter	1
X BO frame spacer (fitted)	1
Water supply hose	1
Water outlet hose	1
Drain filter	1
Hose clip	2
Unit mounting plate	2
Installation templates	1
Operating and installation instructions	1

Tab. 9.1 Scope of delivery

Checking the scope of delivery

- Make sure the delivery is complete and check it for damage.
- Immediately notify the BORA Service Team if parts are missing or damaged.
- Do not under any circumstances install parts which are damaged.
- Dispose of transport packaging in the proper manner (see "10 Decommissioning, disassembly and disposal").

9.3 Tools and aids

The following tools are required to correctly install the appliance, among others:

- Spirit level
- 4 mm Allen key
- Slotted screwdriver
- Water pump pliers

i All installation work must be carried out using hand tools. If machine tools are used, there is a risk of exceeding the tightening torque.

9.4 Installation dimensions

i The minimum appliance installation depth is 565 mm. When using a 560-mm-deep standard unit, you should allow for clearance from the wall. This generally depends on the specific installation and/or the number of X BO frame spacers used.

- Prepare the fitted unit taking into account the dimensions specified.
- Remove the back panel of the unit to the installation recess of the appliance.
- Maintain a minimum distance of 30 mm from the back of the appliance, the back panel of the unit and the shelves to the adjacent elements (unobstructed ventilation cross-section). Shorten the shelves if necessary.

- So that the fill level is detected correctly, use a spirit level to precisely adjust the shelf on which the appliance is to sit.

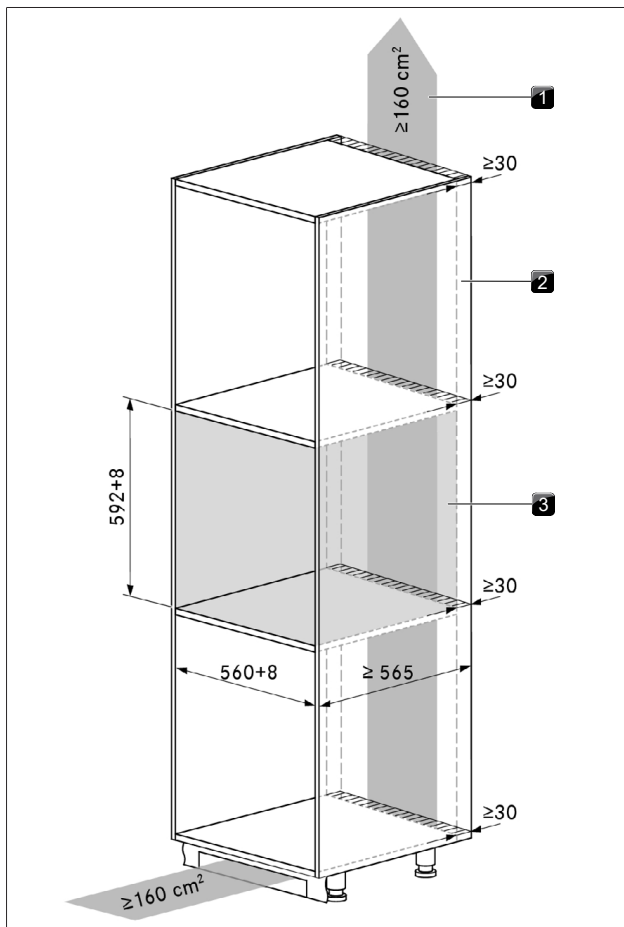

Fig. 9.1 Fitted unit

- [1] Unobstructed ventilation cross-section $\geq 160 \text{ mm}^2$
 [2] Minimum distance of 30 mm
 [3] No unit back panel behind the appliance

9.5 BORA X BO frame spacer

The frame spacers can be used to vary the appliance installation depth. One frame spacer is pre-fitted upon delivery. Depending on the installation situation, it can be removed or an additional frame spacer can be fitted (available as an accessory).

- i** For greater accessibility, the frame spacer should be fitted or removed before installing the appliance.

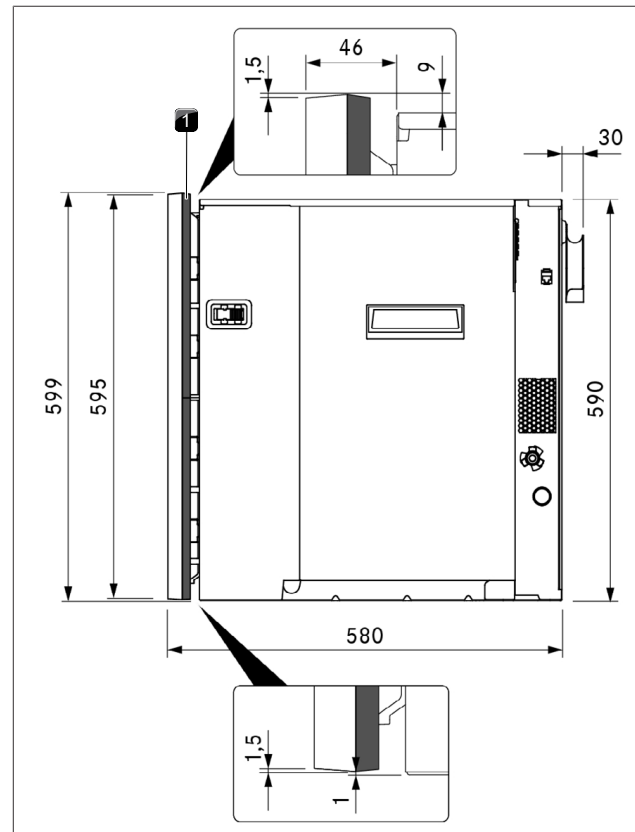

Fig. 9.2 Appliance dimensions

- [1] Frame spacer

Installation depth without frame spacer

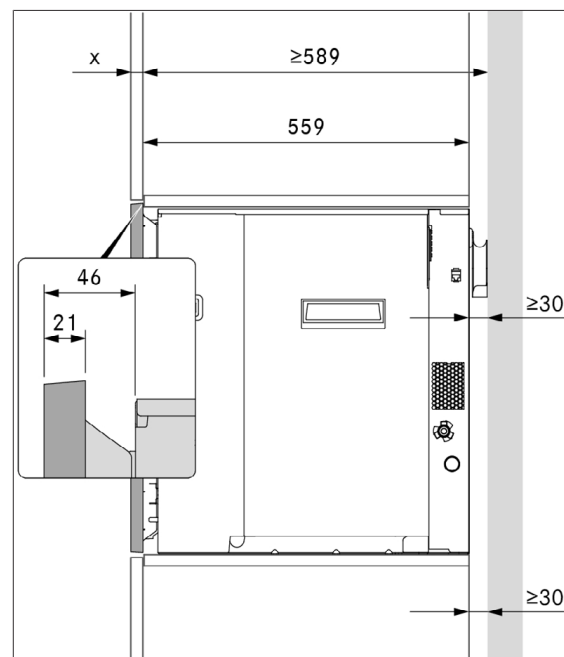

Fig. 9.3 Installation dimensions without frame spacer

Installation depth with one frame spacer

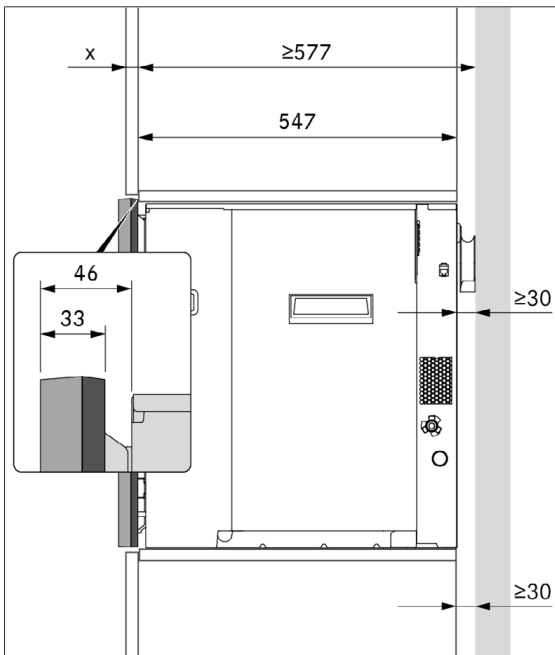

Fig. 9.4 Installation dimensions with 1 frame spacer

Installation depth with 2 frame spacers

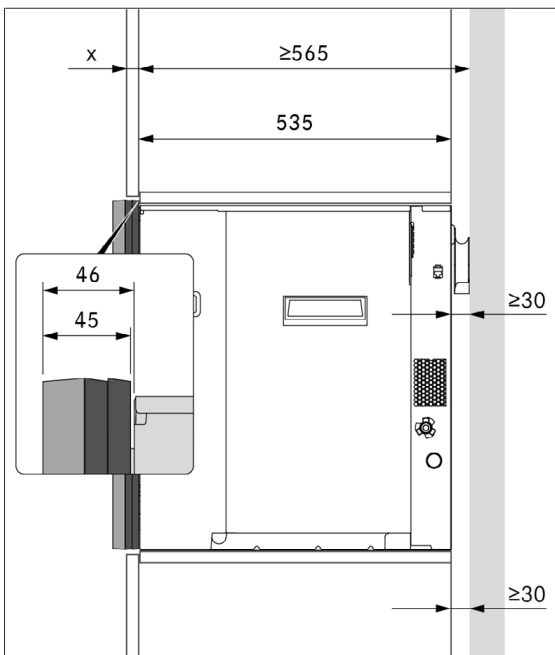

Fig. 9.5 Installation dimensions with 2 frame spacers

9.5.1 Removing the frame spacer

- Remove the 4 parts of the frame spacer from the corners of the inlay frame by hand.

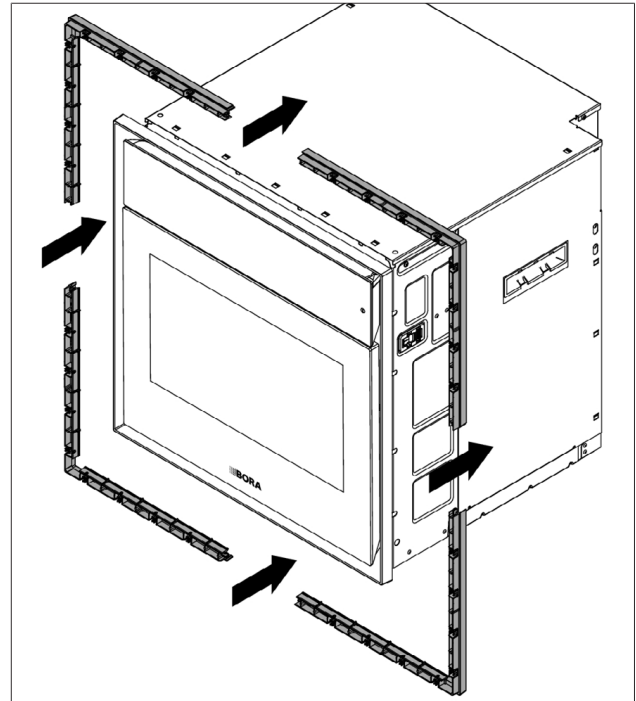

Fig. 9.6 Removing the frame spacer

9.5.2 Fitting additional frame spacers

- Remove the frame spacer from the appliance.
- Attach the corners of the 2 frame spacers to each other and then join all of the corners together.

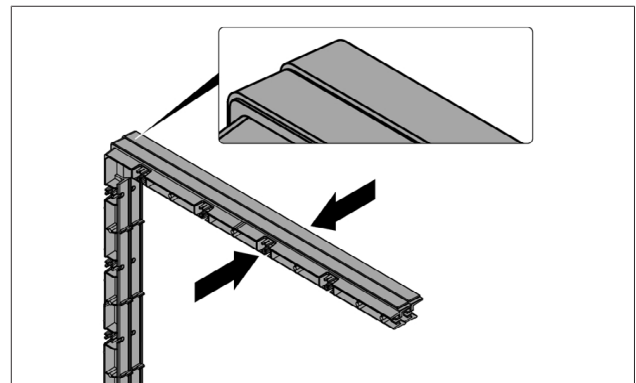

Fig. 9.7 2 frame spacers

- Fit the frame spacers to the inlay frame.

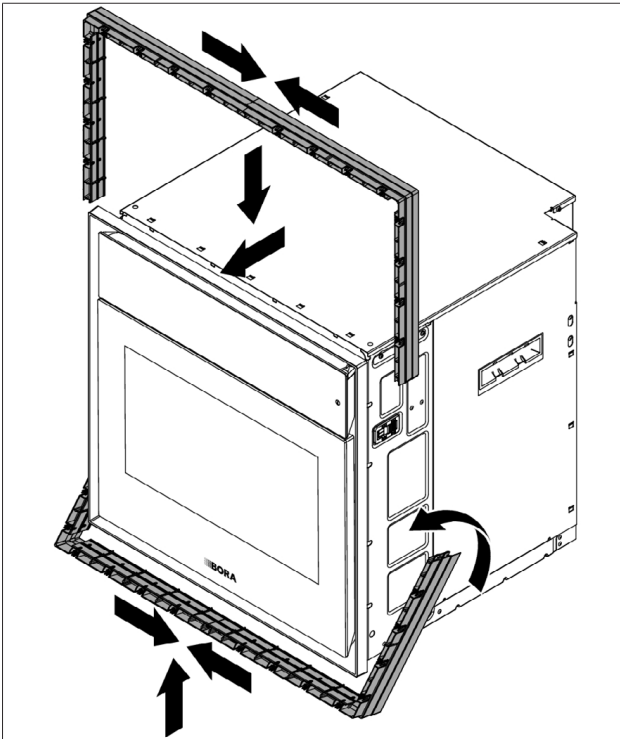

Fig. 9.8 Fitting 2 frame spacers

9.6 Installation

9.6.1 Fitting unit mounting plates

► Using the installation template and the screws provided, screw the unit mounting plates hand-tight to the inside of the installation recess.

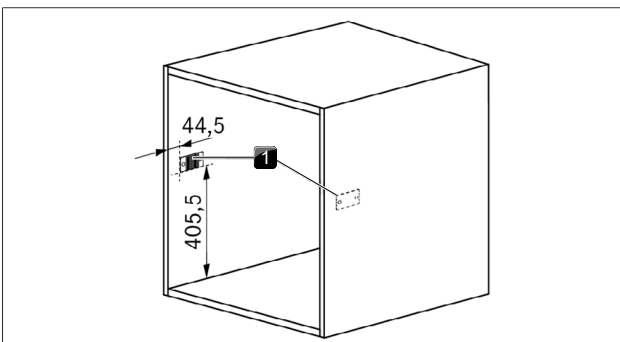

Fig. 9.9 Installation recess with unit mounting plates

[1] Unit mounting plates

9.6.2 Appliance connections

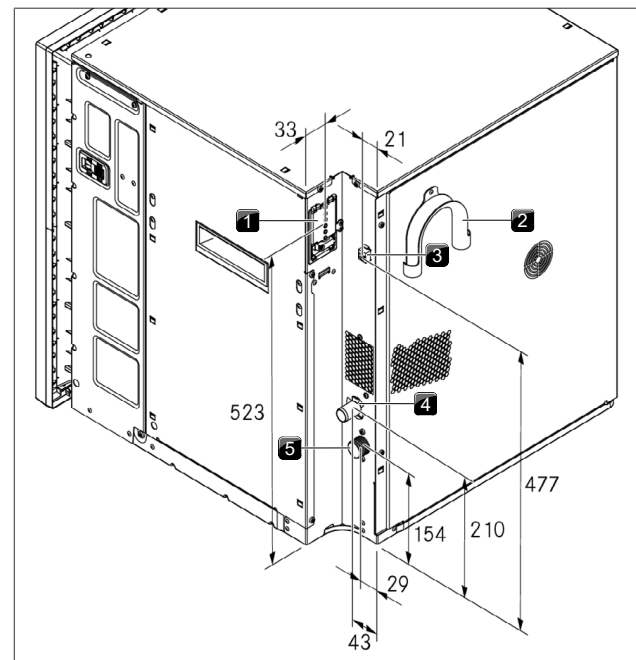

Fig. 9.10 Appliance connections

- [1] Power supply
- [2] Hook for water drainage pipe
- [3] RJ45 connection for BORA multi-drawer (no mains connection)
- [4] Waste water connection
- [5] Fresh water connection

9.6.3 Water drainage

- The waste water trap must be installed at least 100 mm below the waste water connection.
- The water drainage pipe must not be installed above the bottom edge of the appliance.

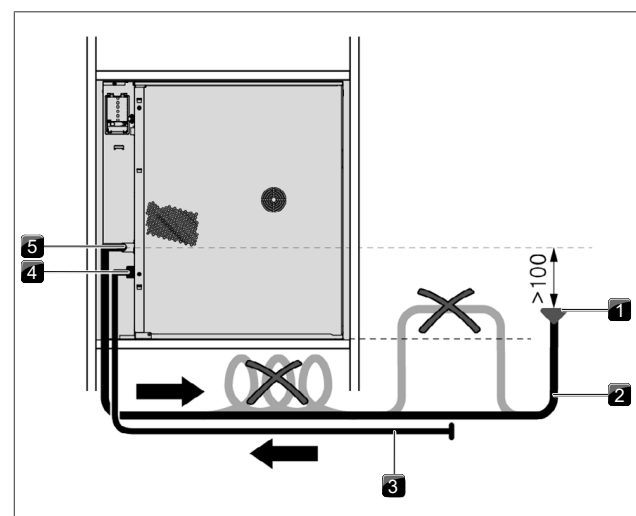

Fig. 9.11 Water drainage

- [1] Waste water siphon
- [2] Water outlet hose
- [3] Water supply hose
- [4] Fresh water connection
- [5] Waste water connection

i If the waste water trap cannot be installed at least 100 mm below the waste water connection, the water drainage pipe must be installed above the hook on back of the appliance. In doing so, it must be ensured that the waste water trap is installed at least 100 mm below the water drainage pipe in the hook.

- Lay the water drainage pipe from the waste water connection so that it goes up over the hook and then back down.

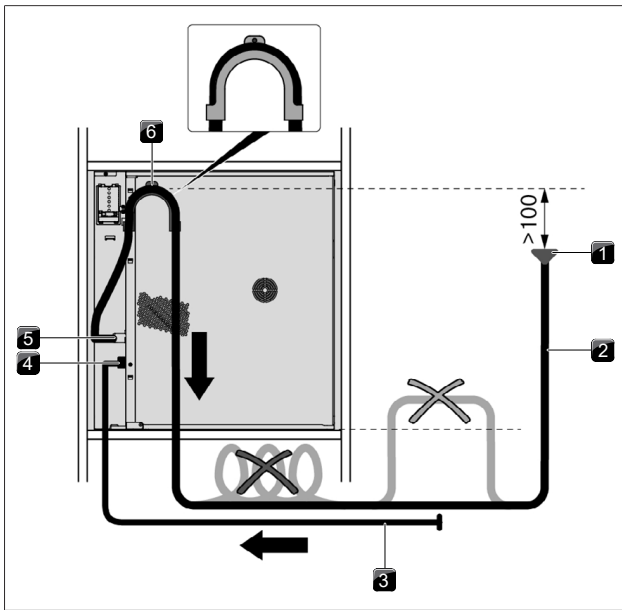

Fig. 9.12 Water drainage via hook

- [1] Waste water trap
- [2] Water drainage pipe
- [3] Water inlet pipe
- [4] Fresh water connection
- [5] Waste water connection
- [6] Hook

9.6.4 Fresh and waste water connection

- Check that the dirt filter is positioned correctly in the water inlet pipe.
- Ensure that there is a washer on each screw connection on the water inlet pipe and that it is positioned correctly.
- If necessary, fit a washer.
- Screw the angled end of the water inlet pipe (facing downwards) to the fresh water connection on the appliance.
- Check that it is screwed on tight and is watertight.
- Using the hose clip, attach the angled end of the water drainage pipe to the waste water connection on the appliance.

The angled end must be facing downwards. If the pre-assembled hook on the back of the appliance is used, the angled end of the pipe must face upwards. The hose clip must only be attached hand-tight.

- Check that the hose clip is firmly in place.

- Ensure that there are no kinks in the hoses.
- Slowly open the stopcock for the fresh water supply and check that the fresh water connection is tightly sealed.
- If necessary, check that the washer and screw connection are firmly in place.

9.6.5 Power supply

- Observe all safety and warning information (see "2 Safety").
- Observe all national and regional laws and regulations as well as the supplementary regulations of the local utility companies.

i The appliances may only be connected to the mains power supply by certified specialists. The specialist also assumes responsibility for the proper installation and commissioning.

i Connections via plug-in contacts (Schuko plugs) are not permitted.

i Single-phase connection: the appliance complies with the requirements of IEC 61000-3-12.

This appliance is intended to be operated on a supply network with an impedance Z_{max} at the transfer point (mains connection) of 0.0416 ohms maximum. The user is to ensure that the appliance is only operated on a power supply network which meets this requirement. If necessary, ask the local energy supply company about the system impedance.

- Switch off the main switch/automatic circuit breaker before connecting the appliance.
- Secure the main switch/automatic circuit breaker against being switched back on without permission.
- Make sure the power to the appliance is disconnected.
- Connect the appliance exclusively via a fixed connection to a power supply cable type H 05 VV-F with corresponding minimum cross-section.

	2-phase connection	Single-phase connection
Fuse protection	2 x 16 A	1 x 16 A
Maximum power consumption	6100 W	3600 W
Minimum cross-section	2.5 mm ²	2.5 mm ²

Tab. 9.2 Fuse protection and minimum cross-section

- Connect the power supply cable to the power supply of the appliance in accordance with the relevant connection diagram.
- Secure the power supply cable with the strain relief clamp.
- Close the power supply housing cover.
- Check that installation has been carried out correctly.

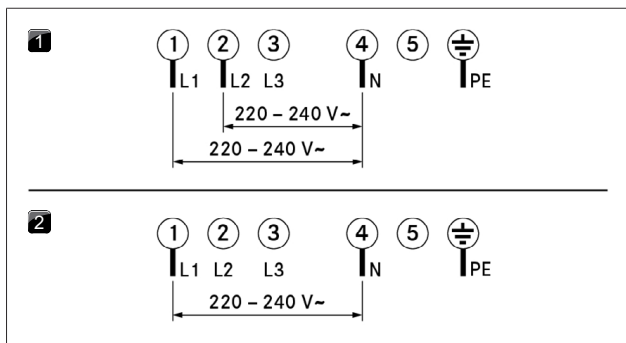

Fig. 9.13 Connection diagrams

- [1] Connection diagram for 2-phase connection, 16 A
 [2] Connection diagram for single-phase connection, 16 A

i Do not use the bridges provided.

9.6.6 How to connect the BORA multi-drawer (optional)

If the BORA X BO is installed in conjunction with a BORA multi-drawer, the two appliances can be connected.

- ▶ Connect the communication cable on the BORA multi-drawer to the RJ45 port on the appliance.

9.6.7 Positioning the operating unit

- ▶ Ensure that there is an even distance of 4 mm between the operating unit and the door.
- ▶ To do this, turn the adjusting screws on the front of the top of the housing.

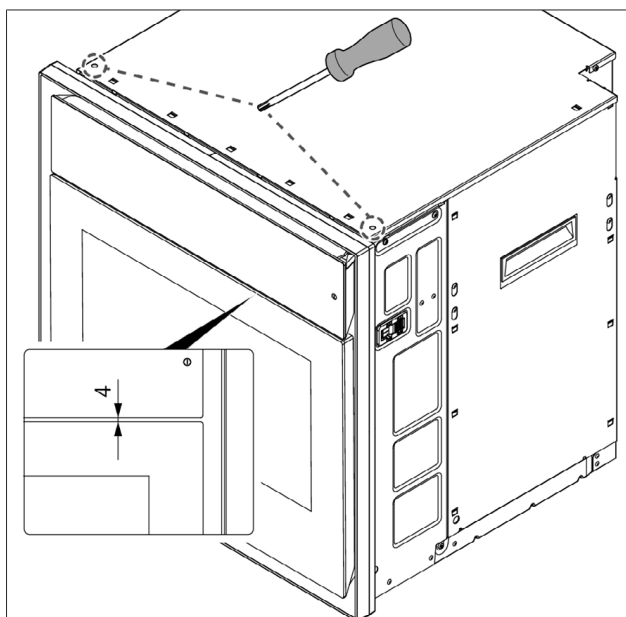

Fig. 9.14 Adjusting the distance between the operating unit and door

9.6.8 Installing and securing the appliance

i The oven chamber seal must not be removed; instead, it should be simply folded down at the top corners.

- ▶ Push the appliance into the desired position in the installation recess.
- ▶ Ensure that the water hoses and power supply cable are not trapped or damaged in doing so.
- ▶ Maintain a minimum distance of 30 mm between the back of the appliance and the adjacent elements.
- ▶ Align the appliance in the centre.
- ▶ Open the door.
- ▶ Fold the top left and right corners of the oven chamber seal down far enough to access the fixing screws.
- ▶ Ensure that you do not pull the oven chamber seal out too far. Turning the fixing screw (4 mm Allen key) causes the levelling shim on the corresponding side to move outwards and press against the locking plate.
- ▶ Fasten the fixing screws tight, alternating sides.
- ▶ Carefully push the corners of the oven chamber seal back into position.
- ▶ Check that the oven chamber seal is positioned correctly all the way round.
- ▶ Check that the appliance is installed correctly.

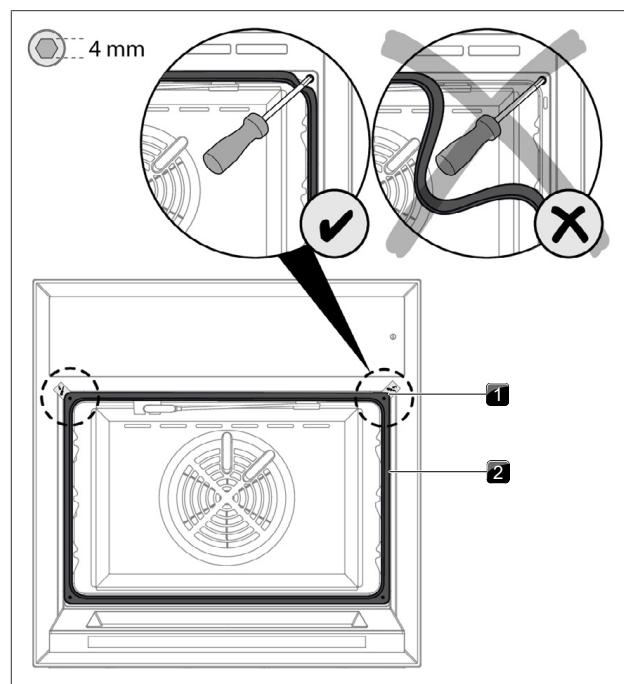



Fig. 9.15 Securing the appliance

- [1] Detachable corner with fixing screws underneath
 [2] Oven chamber seal

9.6.9 Fitting the odour filter

- ▶ Take the new odour filter out of its packaging.
- ▶ Touch “Maintenance” .
- ▶ Touch “Filter change” .
- ▶ Proceed as shown when you press the “Instructions” button.

9.7 Ventilation

- i** Installation must not take place without return flow apertures of $\geq 160 \text{ cm}^2$ in the plinth area and trim.
- Provide for return flow apertures in the plinth area and in the trim on the unit.

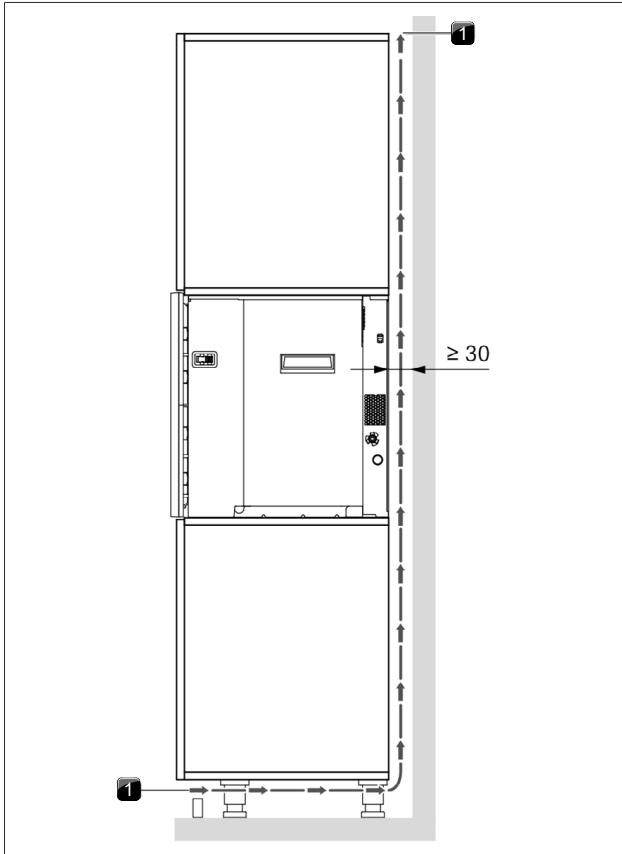

Fig. 9.16 Ventilation

[1] Return flow aperture $\geq 160 \text{ cm}^2$

9.8 Initial operation

When the appliance is switched on for the first time, the following settings can be made:

- Select language
- Activate Wi-Fi
- Set date and time (time format)
- Water settings (degree of hardness)
- Select food preferences

The settings can be changed at a later date.

- Insert the drain filter before using for the first time.
 ► If necessary, update the appliance software.

In rare cases, there may be residues from production in the oven chamber.

- Clean the oven chamber by hand or using a cleaning programme without a cleaning cartridge.

- i** When heating up the appliance for the first time, light smoke and odours may be evident.

9.9 Handover to user

Once installation is complete:

- Explain the main functions to the user.
 ► Explain all safety-related aspects of operation and handling to the user.
 ► Provide the user with the accessories and operating and installation instructions, which are to be kept in a safe place.

10 Decommissioning, disassembly and disposal

- ▶ Observe all safety and warning information (see "2 Safety").
- ▶ Follow the enclosed manufacturer's information.

10.1 Decommissioning

Decommissioning refers to ultimate decommissioning and disassembly. Following decommissioning, the appliance can either be installed in another unit, sold on privately or disposed of.

- i** The electricity connection may only be disconnected and cut off by certified specialists.
- ▶ Switch the appliance off before decommissioning (see operating instructions)
- ▶ Disconnect the appliance from the power supply.

10.2 Disassembly

To be removed, the appliance must be accessible for disassembly and disconnected from the power supply.

- ▶ Close the fresh water supply stopcock.
- ▶ Remove the two fixing screws top left and right behind the oven chamber seal.
- ▶ Move the appliance slightly from side to side to bring the shims back to their starting position.
- ▶ Remove any other accessories.
- ▶ Dispose of the old appliance and any soiled accessories as described under "Environmentally-friendly disposal".

10.3 Environmentally-friendly disposal

10.3.1 Disposal of transport packaging

- i** The packaging protects the appliance from damage during transport. The packaging materials have been selected taking into account the environment and their disposal and are therefore recyclable.

Recycling the packaging saves raw materials and reduces waste. Your specialist retailer will take the packaging back.

- ▶ Give the packaging to your specialist retailer or
- ▶ dispose of the packaging correctly observing regional regulations.

10.3.2 Disposal of accessories

Dispose of unnecessary or used accessories (activated charcoal filters, etc.) accordingly taking into account the regional regulations.

10.3.3 Disposal of the old appliance



Electrical appliances with this mark must not be disposed of in the household waste at the end of their service life. They must be disposed of at a collection point for the recycling of electrical or electronic appliances. Information on this can be obtained from the city or local councils.

Waste electrical and electronic appliances often still contain valuable materials. However, they also contain harmful substances that were necessary to make them work and ensure their safety. If placed in the household waste or handled incorrectly, they may harm human health and damage the environment.

- ▶ Never dispose of your old appliance in the household waste.
- ▶ Take the appliance to a regional collection point for the return and further processing of electrical and electronic components and other materials.

11 Warranty, technical service, spare parts, accessories

► Observe all safety and warning information (see "2 Safety").

11.1 BORA manufacturer's warranty

BORA provides its end customers with a 2-year manufacturer's warranty for its products. The end customer is entitled to this warranty in addition to the statutory claims for defects against the sellers of our products.

The manufacturer's warranty applies to the BORA products listed here, which are sold by authorised BORA retailers or by BORA trained salespersons and are installed within the European Union (overseas territories excluded), Switzerland, Liechtenstein, Ukraine, Russia, Norway, Serbia, Israel, UK, Iceland, India, Australia and New Zealand, with the exception of BORA products labelled as universal or accessories:

- BORA X BO steam oven

The manufacturer's warranty starts as soon as the BORA product is handed over to the end customer and is valid for 2 years. Registering on www.mybora.com enables the manufacturer's warranty to be extended to 3 years.

The manufacturer's warranty requires expert installation (in accordance with the valid BORA planning guide and operating instructions at the time of installation) of the BORA products by an authorised BORA retailer. During use, the end customer is to adhere to the specifications and instructions in the operating manual. When filing a warranty claim, BORA must be directly notified of the fault and the receipt must be presented. Alternatively, proof of purchase can be provided by registering on www.mybora.com. BORA guarantees that all BORA products are free from material and production defects. The defect must exist prior to delivery of the product to the end customer. Filing a warranty claim does not interrupt the warranty period, nor shall the period start anew. BORA will correct defects in BORA products at its own discretion by repairing or replacing the product. All costs for the correction of defects under the manufacturer's warranty shall be assumed by BORA.

Expressly not covered by the BORA manufacturer's warranty are:

- BORA products that were not sold by authorised BORA dealers or salespersons trained by BORA
- Damage caused by non-adherence to the operating instructions (including product care and cleaning). This represents improper use.
- Damage caused by normal use
- Damage caused by external influences (such as transport damage, improper removal and installation, ingress of condensation, damage caused by the elements such as a lightning strike)
- Damage caused by repairs carried out by the owner, repairs or attempts to repair carried out by staff not authorised by BORA or companies not authorised by BORA .
- Damage caused by water or dirt due to missing covers or elements
- Damage caused by water placed inside the oven chamber
- Damage caused by extending the water supply and drainage hose without drinking water certification or by extending non-specified pipes with an adapter

- Damage to plastic frames, glass components, metal components (coated and uncoated), the touch display, plastic and other wearable parts
 - Damage caused by electrical voltage fluctuations
 - Secondary damage or claims for damages beyond the defect
- Legal claims, particularly statutory claims for defects or product liability are not limited by the warranty and can be asserted free of charge.

If a defect is not covered by the manufacturer's warranty, a claim may be made against the BORA Technical Service.

BORA shall not assume the resulting costs.

The laws of the Federal Republic of Germany apply to these warranty conditions.

You can contact us at:

BORA Vertriebs GmbH & Co KG, Innstraße 1, 6342 Niederndorf, Austria

- Telephone: 00800 7890 0987
Monday to Thursday from 08:00-18:00 and Friday from 08:00-17:00
- Email: support@bora.com

11.1.1 Warranty extension

You can extend the warranty by registering at www.bora.com/registration.

11.2 Service

BORA Service:

see reverse side of operating and assembly instructions



► In the case of faults you cannot fix yourself, contact your BORA specialist retailer or the BORA Service Team Team.

The BORA Service Team Team will require the type designation and serial number of your appliance (FD number).

You can find both details on the nameplate on the warranty sheet and in the main "Settings" menu under "System and updates".

11.3 Spare parts

- Only use original spare parts for repairs.
- Repairs may only be carried out by the BORA Service Team.

i Spare parts can be obtained from your BORA dealer, the BORA online service website at www.bora.com/service or by calling the service number provided.

11.4 Accessories

- X BO cleaning cartridge (6 piece) XBORK/6
- X BO cleaning cartridge (12 piece) XBORK/12
- X BO odour filter XBOGF
- X BO perforated stainless steel steamer tray XBOGBG
- X BO oven rack XBOBGR
- X BO universal tray XBOUB
- X BO deep universal tray XBOUBT
- X BO frame spacer XBORS

12 Product datasheet

Product information according to Commission Delegated Regulation (EU) No. 65/2014 and Regulation (EU) No. 66/2014.

Manufacturer		BORA	
Model identification		X BO	
Type of oven		Steam oven	
Number of oven chambers		1	
Heat source of each oven chamber		Electricity	
	Symbol	Value	Unit
Appliance mass	M	47.0	kg
Volume of each oven chamber	V	53	l
Energy consumption			
Energy consumption in conventional mode	EC _{electric cavity}	*	kWh/cycle
Energy consumption in fan mode	EC _{electric cavity}	0.74	kWh/cycle
Energy efficiency index of each oven chamber	EEl _{cavity}	94.8	-
Energy efficiency class	-	A	-

Tab. 12.1 Energy labelling

* Does not apply to this product.

13 Information for testing institutes

Product standard	Temperature	Humidity	Time* /core temperature	Food support	Shelf guide
Broccoli	98 °C	100 %	9 min	Perforated stainless steel tray	Middle
Frozen peas	100 °C	100 %	85 °C	Perforated stainless steel tray	Middle

Tab. 13.1 Test food acc. to EN 60350-1

Product standard	Temperature	Humidity	Time* /core temperature	Food support	Shelf guide
Apple tart (partial load)	150 °C	40 %	90 °C	Oven rack	Middle
Apple tart (full load)	160 °C	40 %	90 °C	Oven rack	Middle and bottom
Sponge cake	150 °C	20 %	35 min	Oven rack	Middle
Small cake (full load)	150 °C	0 %	25 min.	Universal tray/deep universal tray	Middle
Spritz cookies	150 °C	20 %	20 min.	Universal tray	Middle

Tab. 13.2 Test food acc. to EN 50304/EN 60350-1

* All times include the preheating time.

Notes



Operating and installation instructions:

○Original

⊙Translation

Manufacturer: BORA Vertriebs GmbH & Co KG

The distribution and duplication of this document, as well as the use and disclosure of its contents are prohibited unless expressly authorised. Great care was taken when devising these operating and installation instructions. However, it may be the case that later technical changes have not yet been added or the corresponding contents have not yet been modified. We apologise for this. An up-to-date version can be requested from the BORA Service team. Misprints and errors excepted.

© BORA Vertriebs GmbH & Co KG

All rights reserved.

D

BORA Lüftungstechnik GmbH

Rosenheimer Str. 33
83064 Raubling
Deutschland
T +49 (0) 8035 / 9840-0
F +49 (0) 8035 / 9840-300
support@bora.com
bora.com

A

BORA Vertriebs GmbH & Co KG

Innstraße 1
6342 Niederndorf
Österreich
T +43 (0) 5373 / 62250-0
F +43 (0) 5373 / 62250-90
support@bora.com
bora.com

INT

BORA Holding GmbH

Innstraße 1
6342 Niederndorf
Austria
T +43 (0) 5373 / 62250-0
F +43 (0) 5373 / 62250-90
support@bora.com
bora.com

AU NZ

BORA APAC Pty Ltd

100 Victoria Road
Drummoyn NSW 2047
Australia
T +61 2 9719 2350
F +61 2 8076 3514
info@boraapac.com.au
bora-australia.com.au

